

Polytron Transmitter Ex and Ex R Instructions for Use



Contents

For Your Safety	4
Intended Use	5
Device Concept	6
Hints for Safe Use	7
Transmitter Polytron Ex	7
Transmitter Polytron Ex R	7
Transmitter Polytron Ex and Ex R	7
Installing Transmitters Polytron Ex resp. Ex R	9
Transmitter Polytron Ex resp. Sensing Head SE Ex:	9
Mounting of the Transmitter Polytron Ex	9
Mounting of the Transmitter Polytron Ex R	10
Mounting the Sensing Head SE Ex	10
Installing Electrical Connections	11
Connection between Transmitter and Central Unit	11
3-Wire Connection	11
4-Wire Connection	12
Connection between Transmitter Polytron Ex R and Sensing Head SE Ex ...	13
Installing Ex-sensor in the Transmitter	13
Adjustment of Constant Current	14
Start-Up	15
Calibrating Transmitter Polytron Ex	15
Zero Adjustment	15
Sensitivity Adjustment	15
Following Completion of Calibration:	16
Calibrating Transmitter Polytron Ex R	16
Zero Adjustment	16
Sensitivity Adjustment	17
Following Completion of Calibration:	17
Check the Measured Value Output	18
Testing the Constantly Amplified Sensor Signal (Sensitivity)	18
Following Completion of Test:	19
Operational Use	20
Using the dust filter	20
Interruptions in Operation	20

Maintenance 21

Ex-sensor Replacement22

 Transmitter Polytron Ex 22

 Transmitter Polytron Ex R 22

Fault – Cause – Remedy 23

Technical Data 24

Transmitter Polytron Ex and Ex R24

Ex-sensors25

 Ex-sensor PR M 25

 Ex-sensor LC M 25

Sensing Heads SE Ex26

Dimensions26

Measuring other gases and vapours27

 Transmitter Ex / Ex R 28

 Sensing Head SE Ex 29

Design and Mode of Operation 30

Principle of Operation30

Order List 31

Accessories31

Calibration Accessories31

Spare Parts31

EC Type-Examination Certificate BVS 03 ATEX E 160 X 32

Declaration of Conformity 36

Index 37

For Your Safety

Strictly follow the Instructions for Use

Any use of the instrument requires full understanding and strict observation of these instructions.

The instrument is only to be used for purposes specified here.

Maintenance

The transmitter must be inspected and serviced regularly by trained service personnel.

Repair of the instrument may only be carried out by trained service personnel.

We recommend that a service contract be obtained with DrägerService and that all repairs also be carried out by them.

Only authentic Dräger spare parts may be used for maintenance.

Observe chapter "Maintenance".

Use in areas subject to explosion hazards

Equipment or components which have been tested and approved according to the national or European regulations on electrical equipment in potentially explosive atmospheres, may be used only under the conditions specified here.

Modifications of components or the use of faulty or incomplete parts are not permitted.

In the case of repairs to equipment or components of this type, the national regulations must be observed.

Liability for proper function or damage

The liability for the proper function of the instrument is irrevocably transferred to the owner or operator to the extent that the instrument is serviced or repaired by personnel not employed or authorized by DrägerService or if the instrument is used in a manner not conforming to its intended use.

Dräger cannot be held responsible for damage caused by non-compliance with the recommendations given above.

The warranty and liability provisions of the terms of sale and delivery of Dräger are likewise not modified by the recommendations given above.

Dräger Safety AG & Co. KGaA

Intended Use

- For stationary, continuous monitoring for concentrations of combustible gas/air or vapour/air mixtures below the **Lower Explosive Limit (LEL)**.
- Transmitter with 4 to 20 mA interface enabling 3- or 4-wire technique.
- Transmitter Polytron Ex R (R = Remote) with remote sensing head SE Ex for applications where sensing head and transmitter have to be placed at different locations.
- Measuring range 0 to 99 % LEL or 0 to 9.9 % LEL

Depending on the Ex-sensor (Polytron Ex) resp. sensing head SE Ex (Polytron Ex R) a measuring range of 0 to 99 or 0 to 9.9 % LEL can be realized.

Type of transmitter	Measuring range 0 to 99 % LEL	Measuring range 0 to 9.9 % LEL
Polytron Ex	Ex-sensor PR M	Ex-sensor LC M
Polytron Ex R	Sensing head SE Ex PR M ET	Sensing head SE Ex LC M

Remark:

The measuring range 0 to 9.9 % LEL is displayed without a decimal point as an integer value between 0 and 99.

- The sensing head SE Ex PR M ET resp. sensing head SE Ex LC M is connected to the transmitter Polytron Ex R by means of a cable of max. 10 m length.

In conjunction with a central controller (e.g. Polytron or Regard):

- Alarm is activated before ignitable concentrations can form.
- Automatic initiation of counter measures which preclude the possibility of an explosion.
- Special calibration mode (inhibition of alarms, one-man-calibration).

Device Concept

The following graphics show the different concepts of the transmitters Polytron Ex and Polytron Ex R.

Transmitter Polytron Ex with display to be used in applications where the display and the point of detection are well accessible for the user:

- Transmitter Polytron Ex with Ex-sensor PR M

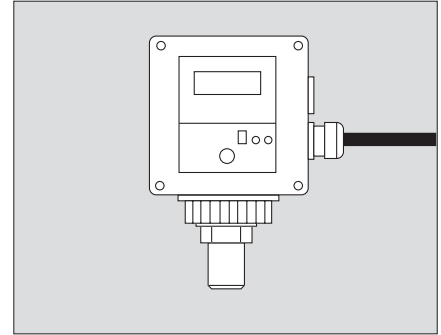

- Transmitter Polytron Ex with Ex-sensor LC M

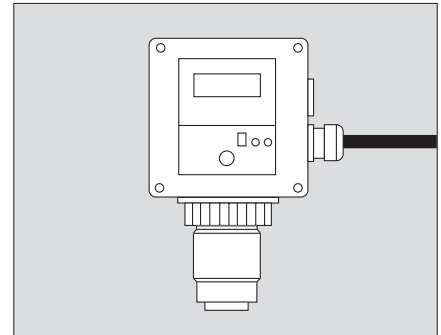

Transmitter Polytron Ex R with remote sensing head SE Ex to be used in applications where the point of detection is not easily accessible for the user:

- Transmitter Polytron Ex R with sensing head SE Ex PR M ET

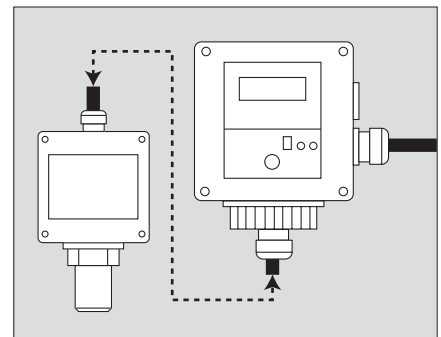

- Transmitter Polytron Ex R with sensing head SE Ex LC M

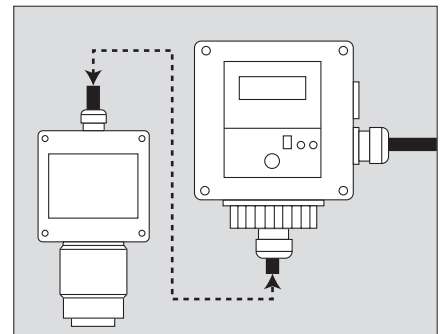

Hints for Safe Use

Transmitter Polytron Ex

The transmitter Polytron Ex is intended to be used for the detection of flammable gases and vapours under atmospheric conditions. The Ex-sensor is connected to the intrinsically safe terminals K11, K12, and K13.

Only an Ex-sensor approved by its own is allowed to be connected to the terminals K11, K12 und K13 of the transmitter Polytron Ex. Installing the Ex-sensor it has to be ensured that a protection class of at least IP 20 acc. to EN 60 529 is maintained.

It is not allowed to install a connecting cable between Ex-sensor and transmitter. For this purpose exclusively the Polytron Ex R transmitter is suitable.

Non-observance will affect the ex-approval!

Transmitter Polytron Ex R

The transmitter Polytron Ex R is intended to be used for the detection of flammable gases and vapours under atmospheric conditions. The sensing head is connected to an inseparably connected cable.

It is not allowed to lengthen the 10 m connecting cable of this intrinsically safe circuit.

Non-observance will affect the ex-approval!

Transmitter Polytron Ex and Ex R

The non-intrinsically safe power supply and signal transmission (current loop 4 to 20 mA) is possible by means of one 3-wire or two 2-wire cables which are connected to the terminals K1, K2, K3, and K4 within a terminal box of protection type "e". The measured value is readable on a display.

At the non-intrinsically safe terminals of the transmitters Polytron Ex resp. Ex R only electrical devices may be connected which even in case of failure have no voltages of higher than 250 V AC.

The transmitters Polytron Ex and Polytron Ex R must not be operated at temperatures lower than $-40\text{ }^{\circ}\text{C}$ or higher than $65\text{ }^{\circ}\text{C}$.

Certain substances in the atmosphere to be monitored may impair the sensitivity of the sensing heads with Ex-sensor PR M resp. Ex-sensor LC M.

The following substances are known at present:

- a) Polymerizing substances such as Acrylo nitrile, Butadiene and Styrene,
- b) Catalyst poisons such as sulphurous or phosphorous compounds, halogenated hydrocarbons, silicon compounds, and metal-organic vapours.

If such substances are expected to occur in the atmosphere to be monitored, the calibration intervals should be shortened. This is also recommended by the European Standard EN 50 073.

Intrinsic Safety Concept:

- Explosion protection acc. to CENELEC:
Transmitter Polytron Ex: EEx me [ib] IIC T4
Transmitter Polytron Ex R: EEx me [ib] IIB T4
- Sensor replacement and maintenance is possible without switching off the supply voltage.

The transmitters Polytron Ex resp. Polytron Ex R with sensing head SE Ex is marked by the device category **II 2G** and is suitable to be operated in hazardous zones 1 and 2.

The ex-approval is valid for the transmitters resp. sensing heads being operated in mixtures of flammable gases and vapours in air. Especially the ex-approval is not valid for the operation in oxygen enriched atmospheres.

Transmitter with measurement function for explosion protection according to 94/9/EC

Only the transmitter Polytron Ex (order no. 83 17 517) mit dem Ex-Sensor PR M (Sachnummer 68 09 225) with the Ex-sensor PR M (order no. 68 09 225) has been certified in the 1st supplement to the EC type test certificate BVS 03 ATEX E 160 X as suitable for use with the following gases and vapours as regards the measurement function for explosion protection:

Methane, propane, hydrogen, n-butane, ethene (ethylene) dimethylether, acetone, ammonia, gasoline 065/095 (FAM petrol), benzene, 1,3-butadiene, cyclopropane, diethylether, acetic acid-n-butylester (ethyl acetate), ethanol, ethyl acetate, ethylene oxide, n-hexane, methanol, methyl ethyl ketone (MEK), n-nonane, n-octane, 2-propanol (isopropanol), propene (propylene), toluene, acetylene, propylene oxide and n-pentane.

The following special conditions must be observed for safe use when using as a transmitter with a measurement function for explosion protection:

1. The heat-of-reaction measuring principle, based on catalytic oxidation of a flammable gas, is not absolutely reliable because at high measured gas concentrations the oxygen concentration in the sensor is no longer sufficient to oxidize the flammable gas. The measuring signal is thus diminished at very high gas concentrations and may reach values inside the measuring range. The downstream controller must be operated with display devices and measured value outputs (if implemented) and alarm outputs which lock if the measuring range is exceeded.
2. The heat-of-reaction measuring principle requires a minimum oxygen content of 12 % V/V. Otherwise too low measured values are displayed, due to the oxygen deficiency.
3. When the supply voltage is switched on, the transmitter may briefly (approx. 100 ms) send a current up to 12 mA to the central unit, exceeding the local alarm thresholds. To avoid this happening, the alarms at the central unit should be locked during the switch-on procedure.

Installing Transmitters Polytron Ex resp. Ex R

- Select installation location in accordance with local regulations.
- Avoid external influences such as splashing water, oil etc. and the possibility of mechanical damage.
- Electrical wiring is only to be laid and connected by an expert paying attention to the pertinent regulations and laws concerning electrical equipment in potentially explosive atmospheres as well as the approval conditions.

Transmitter Polytron Ex resp. Sensing Head SE Ex:

Pay attention to density of gas!

- In case of gases, the density of which is lower than that of air, such as hydrogen, methane or ammonia the transmitter resp. sensing head must be located above a possible leak or at the highest points at which major concentrations of gas may be found.
- In case of gases and vapours with a density greater than that of air, the sensing head resp. transmitter must be installed beneath a possible leak or at the lowest points at which such gases and vapours may be present.

Pay attention to ventilation!

- Always arrange sensing head resp. transmitter in air flow between possible leak or collection point and possible source of ignition.
- Install in vertical position (sensing head with the diffusion surface facing downwards) at a low-vibration location with maximum possible temperature stability (no direct sunlight) in the vicinity of a possible leak.
- Leave at least 30 cm (12") free space beneath the sensing head resp. transmitter to provide accessibility for calibration work.

Mounting of the Transmitter Polytron Ex

- Mount with four screws through the housing
or
- by means of the mounting brackets.

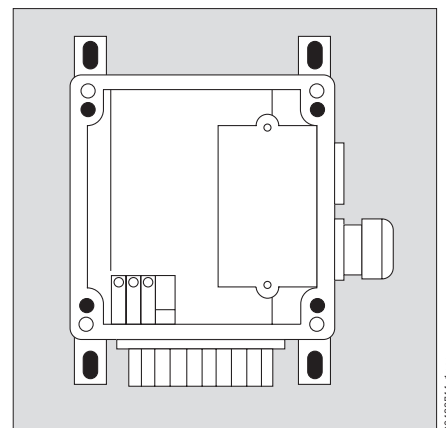

Mounting of the Transmitter Polytron Ex R

- Mount at an accessible place
- Observe maximum length of 10 m of the pre-conditioned connection cable between sensing head SE Ex and transmitter Polytron Ex R.
- Mount with four screws through the housing or
- by means of the mounting brackets.

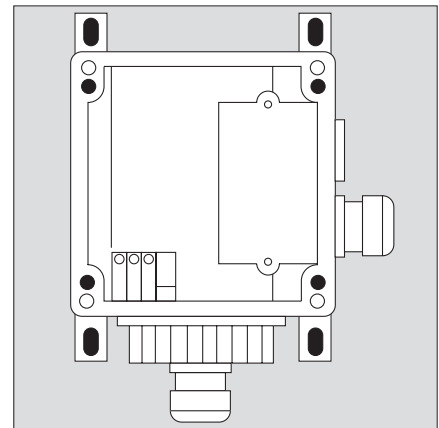

Mounting the Sensing Head SE Ex

- Mount with four screws through the housing.
- Further information concerning installation see installation sheet which is coming with each sensing head SE Ex.

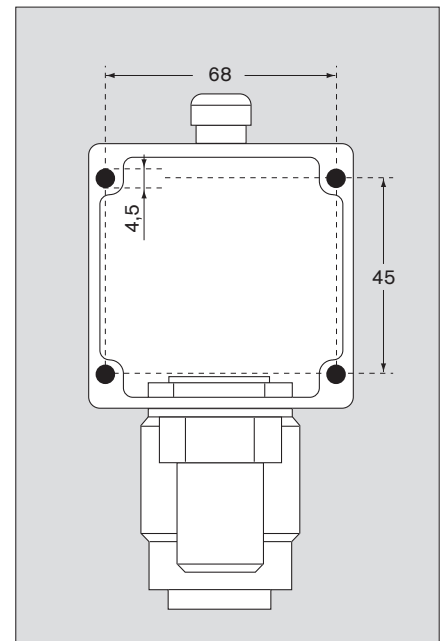

Installing Electrical Connections

Connection between Transmitter and Central Unit

Remark:

- The cable gland is suitable for cable diameters from 7 to 12 mm and must only be used for fixed installations.
- Routing and connecting the electrical installation must only be done by trained personnel, observing appropriate regulations – use 2-, 3- or multi-core, screened cable (braided screen, cover $\geq 80\%$).
- Remove the cover of the transmitter.

On the transmitter:

- 1 Remove two screws from the terminal cover.
 - 2 Remove terminal cover.
- Connect according to the applicable procedure below.
 - After having done the electrical connections mount the terminal cover and fix it with the screws.
 - Observe the tightness of the rubber gasket.
 - Complete installation by fixing the cover of the transmitter with four screws and observe tightness.

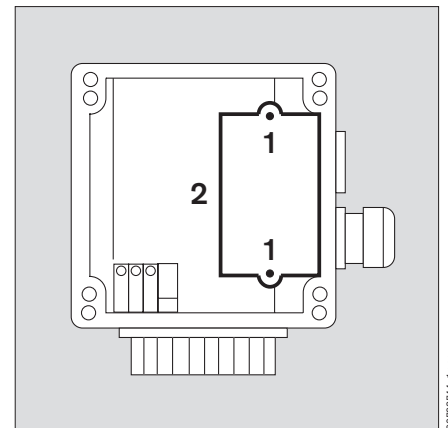

3-Wire Connection

- The cable resistance per core for the connection to the transmitter terminals K1 and K3 must not exceed 20 Ohms.
- The sum total of the input resistance of the central controller and the line resistance of the connection to the transmitter terminal K4 must not exceed 450 Ohms.
- Connect screen to terminal E of the transmitter.
- Ground the transmitter via external terminal, but do not ground screen at the central controller, or
- do not ground transmitter via external terminal, but ground screen in the central controller.
- Central controller and supply unit can also be combined in one unit.

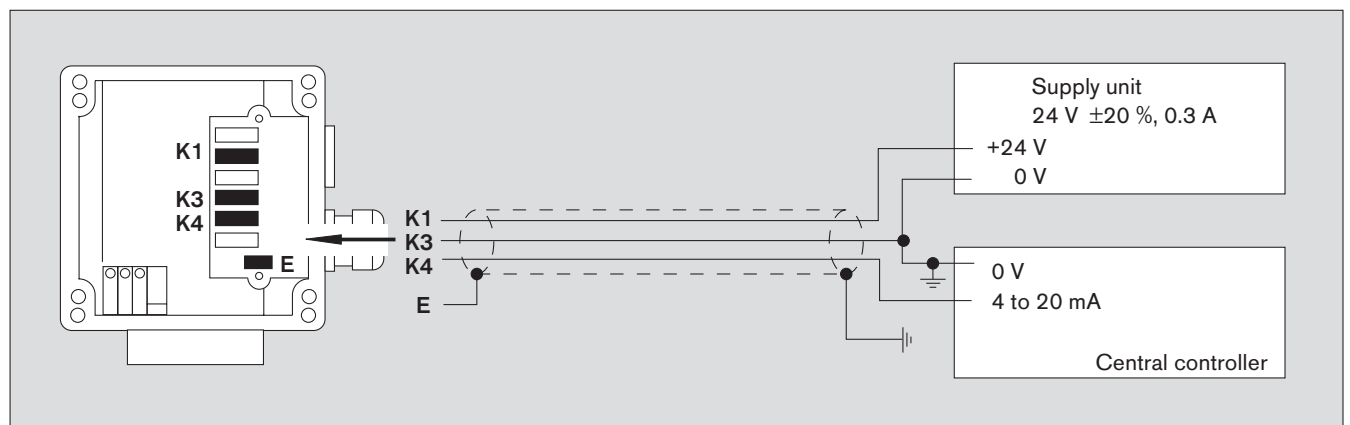

4-Wire Connection

- 1 Remove dummy plug.
- 2 Screw second cable gland (see Order List, page 31) into housing and secure with nut.

Important:

The cable gland is a part of the approved device and only the one listed in the Order List is allowed to be used. It is suitable for cable diameters of 7 to 12 mm.

Non-observance will affect the ex-approval!

- The cable resistance per core for the connection to the transmitter terminals K1 and K3 must not exceed 20 Ohms.
- The sum total of the input resistance of the central controller and the line resistances of both cores for the connection to the transmitter terminals K3 and K4 must not exceed 350 Ohms.
- Connect screen to terminal E of the transmitter.
- Ground the transmitter via external terminal, but do not ground screen at the central controller,
or
- do not ground transmitter via external terminal, but ground screen in the central controller.
- Central controller and supply unit can also be combined in one unit.

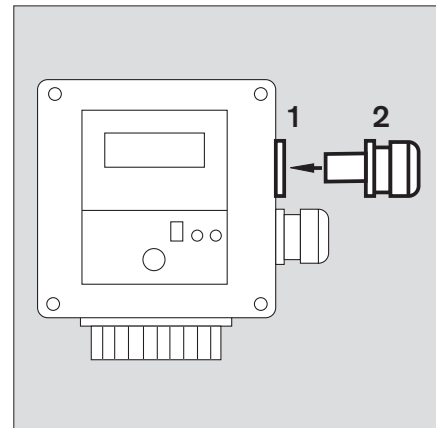

01023744_1.jpg

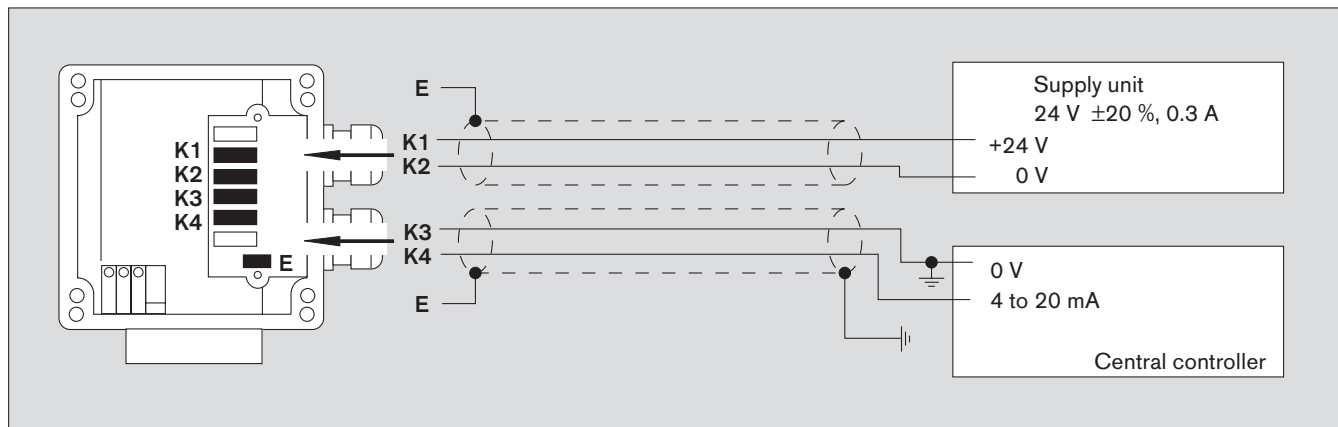

01023744_1.jpg

Connection between Transmitter Polytron Ex R and Sensing Head SE Ex

- Make sure to use such Ex-sensors only which are listed in the Order List, page 31.
- Shorten the cable if required, and attach it in line with the illustration:
 - brown – terminal 1
 - white – terminal 2
 - green – terminal 3

For reasons of ex-protection, the pre-mounted cable must neither be extended nor replaced by another cable.

Non-observance will affect the ex-approval!

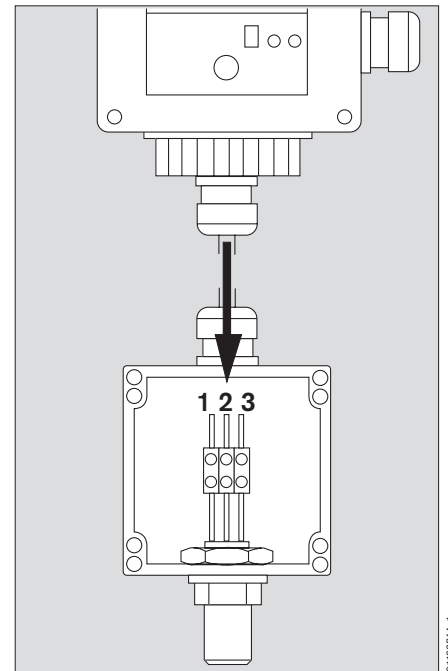

Installing Ex-sensor in the Transmitter

- 1 Loosen hexagon socket-head bolts on upper side and remove upper section.
 - 2 Unscrew bayonet ring, remove cover plate.
 - 3 Remove Ex-sensor from packaging, screw it into the adapter plate delivered with the transmitter, observe gasket and lock with bayonet ring.
- Make sure to use such Ex-sensors only that are specified in the Order List, page 31.
 - Adjust constant current or constant voltage of transmitter according to the specifications in the technical data of the Ex-sensor used:

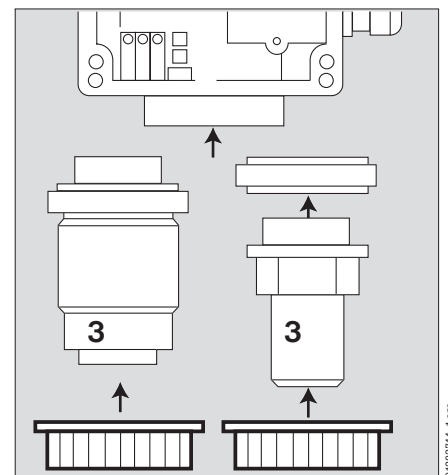
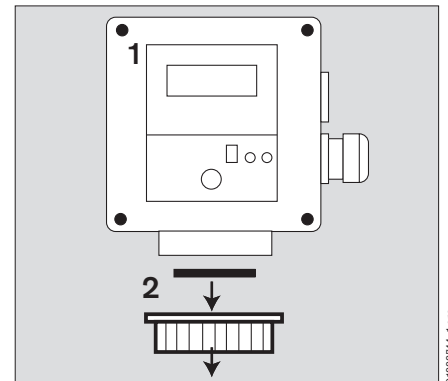

Adjustment of Constant Current

(ex-factory-setting: 270 mA)

Note:

The procedure is valid for the transmitter Polytron Ex and Ex R, however the illustration only shows the transmitter Polytron Ex.

- 1 Check position of jumper and correct if required (ex-factory setting).
- 2 Position jumper according to sensor current (see specifications in technical data of the Ex-sensor used, page 25):

Sensor Current 100 to 140 mA:



Sensor Current 141 to 220 mA:



Sensor Current 221 to 300 mA:
(ex-factory setting)



- 3 Attach cable of Ex-sensor.
 - 4 Connect voltmeter ($R_i \geq 10 \text{ MOhm}$, measurement error $\leq 0,2 \%$) to test points.
 - Switch on power supply.
 - 5 Using potentiometer, adjust voltage at the test points (for 270 mA: 891 mV, for 276 mA: 911 mV).
 - 4 Disconnect voltmeter.
 - 6 Screw upper section onto housing using the hexagon socket-head bolts.
- Repeated adjustment is not necessary if the Ex-sensor is subsequently replaced by an Ex-sensor with the same adjustment current.
 - Sensor replacement can be carried out without interrupting the supply voltage in explosion-hazard areas, since the sensor circuit is intrinsically safe.

The ex-factory setting is Constant current, 270 mA (corresponding to 891 mV)

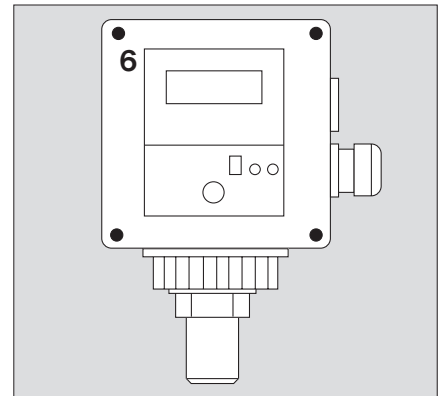
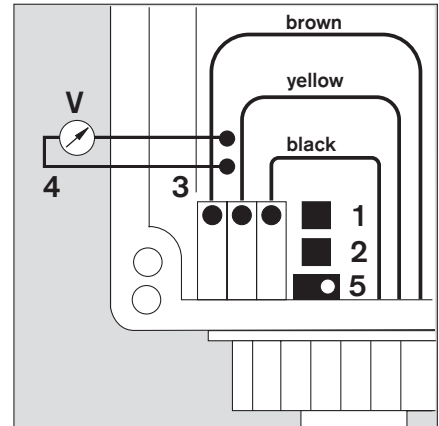

Start-Up

- Switch on supply voltage.
Note: switching on the supply voltage may trigger an alarm at the central unit (see page 8, para. 3).
- Allow transmitter with Ex-sensor to warm-up in this condition for 10 minutes (sensor warm-up time).

Calibrating Transmitter Polytron Ex

- Use special key to open flap in front of adjusters.
- 1 Set sliding switch to position »1« = cal.
- The measurement signal of the 4 to 20 mA loop oscillates between 2.5 mA and 5 mA with approx. 1 Hz, thus preventing alarm triggering.
- A further digit appears in the display making it possible to take more precise readings.

Zero Adjustment

Without calibration adapter:

- Ensure that the transmitter is in clean ambient surroundings, i.e. that there are no combustible gases or vapours present, or
- with calibration adapter:

- Supply clean air at a rate of approx. 0.5 L/min via the calibration adapter.

- 2 Wait for the display to stabilize (max. 3 minutes). Set potentiometer such that the display indicates 00.0.

Sensitivity Adjustment

- Using commercially available test gas:
- Depending on the Ex-sensor used supply the recommended calibration gas concentration (see table below) at a flow rate of approx. 0.5 L/min via the calibration adapter.

Recommended concentrations:

Ex-sensor	Full scale value	Calibration gas concentration
Ex-sensor PR M	100 % LEL	10 to 50 % LEL
Ex-sensor LC M	10 % LEL	3 to 7 % LEL

- The calibration gas must be a mixture of the gas component to be monitored in air. Mixtures with nitrogen are not suitable!

Once measured value display has stabilized (after max. 3 minutes):

- 3 Adjust sensitivity on potentiometer such that display indicates the calibration gas concentration.

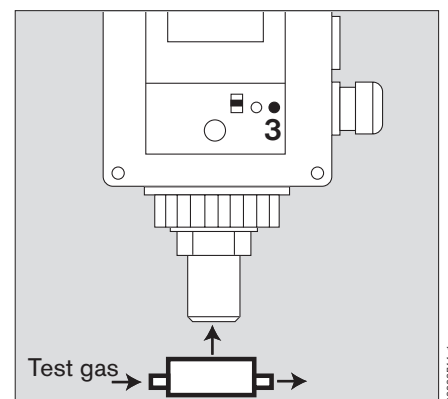
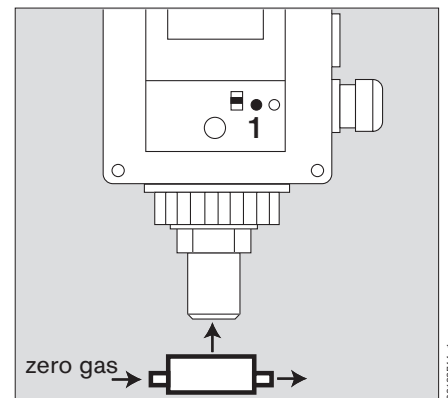
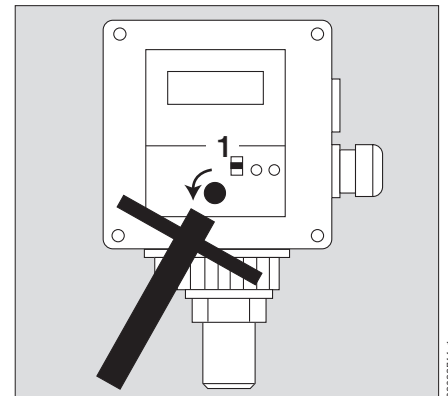

- When using the Ex-sensors LC M:
The gas concentration is display without the decimal point, so the true concentration is a tenth of the reading in % LEL.
- For calibration with solvent vapours, use can be made of the calibration chamber (see Order List, page 31) in which a specified amount of solvent is evaporated, so as to obtain, for example, 50 % LEL.
Adjustment is carried out as for calibration gas.
- The use of a calibration chamber requires appropriate training and knowledge on the part of the operating personnel. Pay attention to usage instructions provided with the calibration chamber!

If it is no longer possible to adjust sensitivity due to inadequate sensor sensitivity (measured value too low),
or
if the measured value display does not stabilize after 3 minutes, the Ex-sensor must be replaced (refer to page 22).

Following Completion of Calibration:

- 1 Set sliding switch to position »0« = normal.
- 2 Use special key to close flap in front of adjusters.

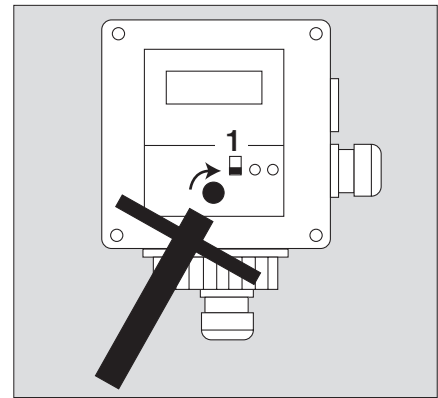

Calibrating Transmitter Polytron Ex R

- Use special key to open flap in front of adjusters.
- 1 Set sliding switch to position »1« = cal.
- The measurement signal of the 4 to 20 mA loop oscillates between 2.5 and 5 mA with approx. 1 Hz, thus preventing alarm triggering.
 - A further digit appears in the display making it possible to take more precise readings.

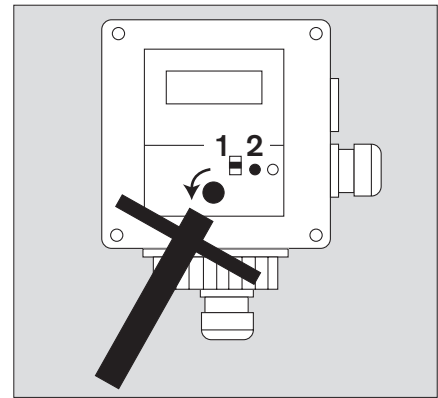

Zero Adjustment

Without calibration adapter:

- Ensure that the sensing head is in clean ambient surroundings, i.e. that there are no combustible gases or vapours present,
or
- with calibration adapter:

- Supply clean air at a rate of approx. 0.5 L/min. via the calibration adapter.
- 2 Wait for the display on the transmitter Polytron Ex R to stabilize (max. 3 minutes). Set potentiometer of the transmitter Polytron Ex R such that the display indicates 00.0.

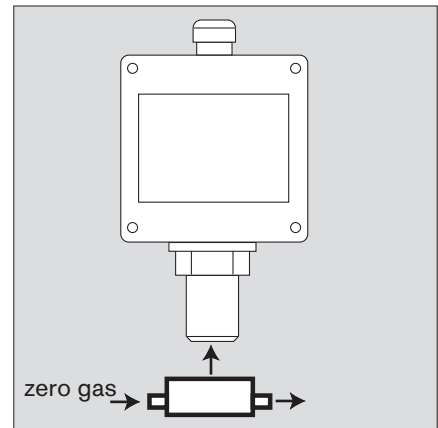

Sensitivity Adjustment

Using commercially available test gas:

- Depending on the sensing head used supply the recommended calibration gas concentration (s. table below) at a flow rate of approx. 0.5 L/min via the calibration adapter.

Recommended concentrations:

Sensing head	Full scale value	Calibration gas concentration
SE Ex PR M	100 % LEL	10 to 50 % LEL
SE Ex LC M	10 % LEL	3 to 7 % LEL

- The calibration gas must be a mixture of the gas component to be monitored in air. Mixtures with nitrogen are not suitable!

Once measured value display has stabilized (after max. 3 minutes):

- 1 Adjust sensitivity on potentiometer of the transmitter Polytron Ex R such that display indicates the calibration gas concentration.

When using the sensing head SE Ex LC M:

- The gas concentration is displayed without the decimal point, so the true concentration is a tenth of the reading in % LEL.
- For calibration with solvent vapours, use can be made of the calibration chamber (see Order List, page 31) in which a specified amount of solvent is evaporated, so as to obtain, for example, 50 % LEL.
Adjustment is carried out as for calibration gas.
- The use of a calibration chamber requires appropriate training and knowledge on the part of the operating personnel. Pay attention to usage instructions provided with the calibration chamber!

If it is no longer possible to adjust sensitivity due to inadequate sensor sensitivity (measured value too low),

or

if the measured value display does not stabilize after 3 minutes, the Ex-sensor must be replaced (refer to page 22).

Following Completion of Calibration:

- 1 Set sliding switch to position »0« = normal.
- 2 Use special key to close flap in front of adjusters.

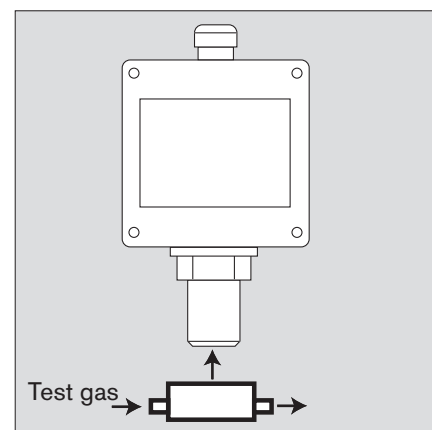

02823744_1_en.jpg

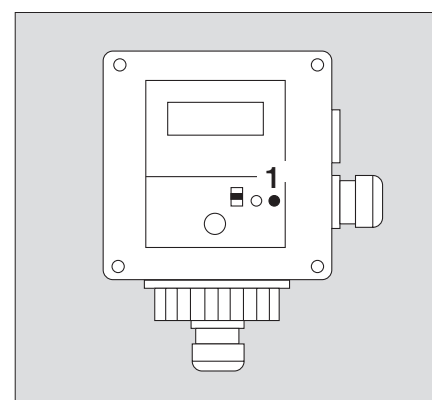

02823744_1.jpg

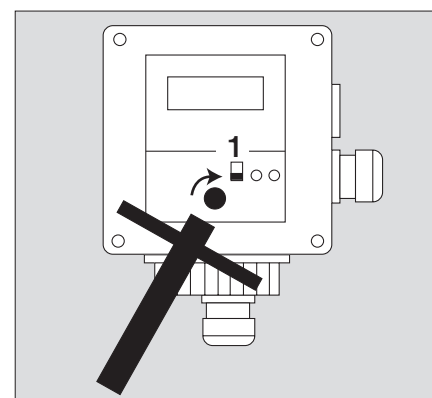

02823744_1.jpg

Check the Measured Value Output

During calibration:

- Compare measured value indicated on the transmitter's display with the reading of the corresponding central unit (e.g. channel module Polytron or Regard) or
- Check alarm triggering by supplying a test gas (concentration somewhat higher than the alarm threshold) to the Ex-sensor.

Testing the Constantly Amplified Sensor Signal (Sensitivity)

- Perform zero calibration as described under "Calibrating Transmitter Polytron Ex" resp. "Calibrating Transmitter Polytron Ex R" (page 15 resp. page 16).
- 1 Set sliding switch to position »2« = test.
- The measurement signal of the 4 to 20 mA loop oscillates between 2.5 and 5 mA with approx. 1 Hz, thus preventing alarm triggering.
- The display shows a 3-digit number without a decimal point.
- Depending on the Ex-sensor used supply the recommended calibration gas concentration (s. table below) at a flow rate of approx. 0.5 L/min via the calibration adapter.

Ex-sensor resp. Sensing head	Full scale value	Calibration gas concentration
Ex-sensor PR M Sensing head SE Ex PR M	100 % LEL	10 to 50 % LEL
Ex-sensor LC M Sensing head SE Ex LC M	10 % LEL	3 to 7 % LEL

- The calibration gas must be a mixture of the gas component to be monitored in air. Mixtures with nitrogen are not suitable!

Once measured value display has stabilized (after max. 3 minutes):

- Divide the displayed value by the gas concentration (in % LEL) to obtain the sensitivity E:

$$E = \frac{\text{Displayed value}}{\text{gas concentration}} \cdot \frac{[1]}{[\% \text{ LEL}]}$$

- Keep sensitivity E for reference purposes when performing repeat measurements during operation period.
- This test must be performed at regular intervals and following repairs. The results are to be compared with the result of the measurement performed on start-up.
- If the sensitivity drops below 50 % of the sensitivity on start-up, then the Ex-sensor is to be replaced.

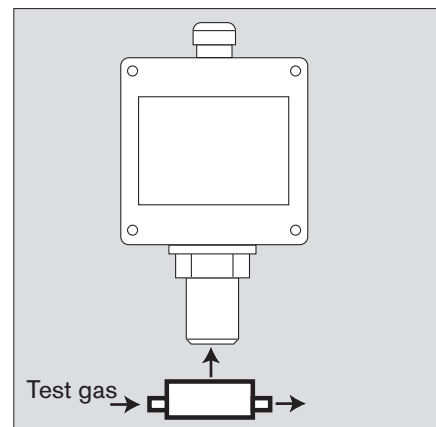
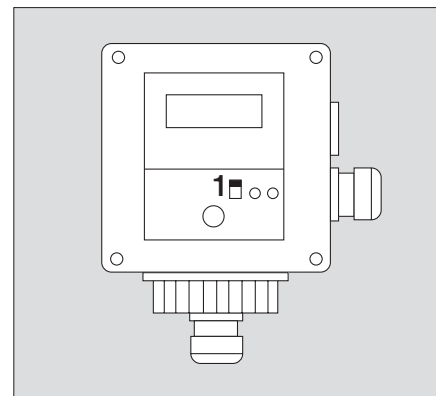
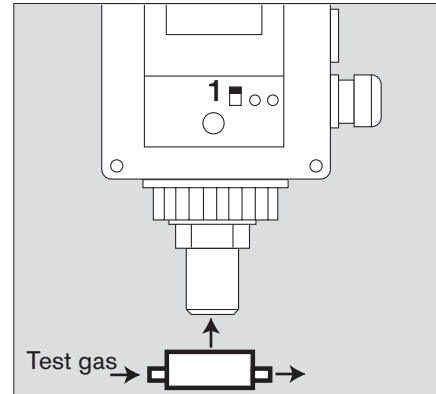

Following Completion of Test:

- 1 Set sliding switch to position »0« = normal.
- Use special key to close flap in front of adjusters.

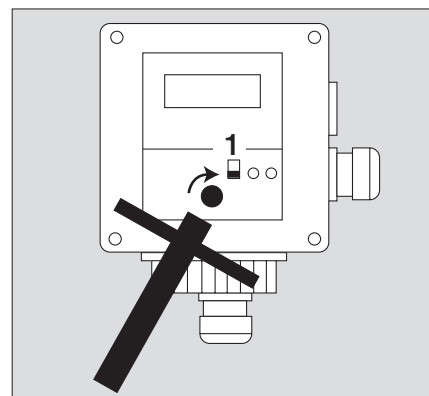

Operational Use

- 1 The display indicates the measured gas concentration,
 - 2 when the sliding switch is set to »0« = normal and »1« = cal.
- A reference number for the constantly amplified sensor signal is indicated when the switch is set to »2« = test.
- 3 A negative signal (dropped below zero) is indicated by a triangle (▼).
 - 4 Exceeding the measuring range is indicated by an arrow (↑).
- A current between 4 and 20 mA flows through the signal current loop in accordance to the gas concentration, i. e.:

Current	Significance
< 3.0 mA	Malfunction
4 mA	Zero
20 mA	Full scale value
> 20 mA	Measuring range exceeded

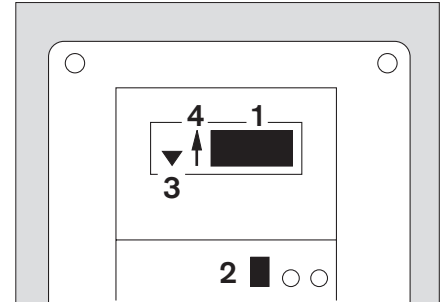

Using the dust filter

A dust filter can be used with the Ex-sensor PR M (see Order List, order no. 68 10 537). This simply presses into place in the opening in front of the sensor sintered metal disc and locks in position. The dust filter has virtually no adverse effect on sensor response times and its influence on sensor sensitivity is minimal. However, if using a dust filter, it must always be in place when calibration is carried out. The dust filter should be replaced before calibration.

Interruptions in Operation

e.g. in the event of repair work

- In the event of interruptions in operation, for example during servicing and inspection, the system is ready for use again after 10 minutes (Ex-sensor warm-up time) following renewed switch on.
- If necessary, the unit must be recalibrated.

Maintenance

- EN 50073 and national regulations applicable must be observed.

Every day

- Visual inspection to check that it is operational.

When using for the first time

- Check the zero adjustment and sensitivity calibration, see page 15 to page 17.
- Check that display on the transmitter matches the display on the central unit.

At regular intervals

to be established by the person responsible for the gas warning system, not exceeding a time interval of six months:

- Check the zero adjustment and sensitivity calibration, see page 15 to page 17. In particular, it is important to check the condition of the sensor sintered metal disc regularly, in case it is impairing gas flow due to corrosion or deposits (such as dust, oil or aerosol).

Every year

- Inspection by trained specialists.

In each case the length of the interval between inspections should be decided according to safety considerations, process conditions and equipment requirements.

We recommend that a service contract be taken out with DrägerService and that all repairs be carried out by DrägerService.

Ex-sensor Replacement

Transmitter Polytron Ex

- Use only Dräger Sensors listed in the Order List page 31.
 - If the Ex-sensor is not to be replaced by a Ex-sensor with the same sensor current or sensor voltage (see page 25), the procedure to be employed is described in the section entitled “Installing Ex-sensor in the Transmitter”, page 13.
 - The procedure outlined below may only be employed if sensor current resp. sensor voltage tally:
 - 1 Loosen hexagon socket-head bolts on upper side and remove top section.
 - 2 Disconnect cable of old Ex-sensor and
 - 3 unscrew bayonet ring – remove Ex-sensor.
 - 4 Remove Ex-sensor from packaging, screw it into the adapter plate of the transmitter, observe gasket and lock with bayonet ring.
 - Make sure to use such Ex-sensors only that are specified in the Order List, page 25.
 - 3 Mount Ex-sensor to the transmitter, observe gasket and lock with bayonet ring.
 - 2 Connect cable of Ex-sensor.
-
- 1 Screw upper section onto housing using hexagon socket-head bolts.
 - The sensor replacement can be carried out without interrupting supply voltage in explosion-hazard areas, since the sensor circuit is intrinsically safe.
 - The transmitter must be calibrated following sensor replacement (see page 15).
 - Allow 10 minutes for new Ex-sensor to warm up.

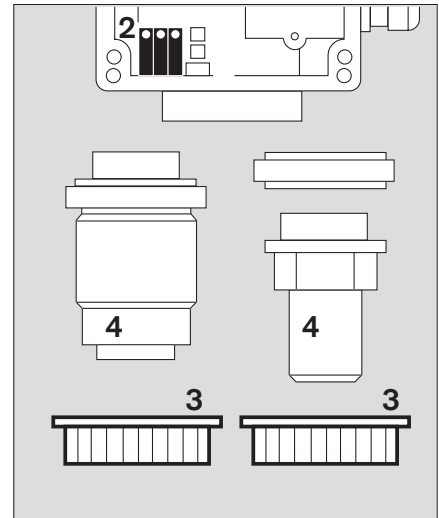
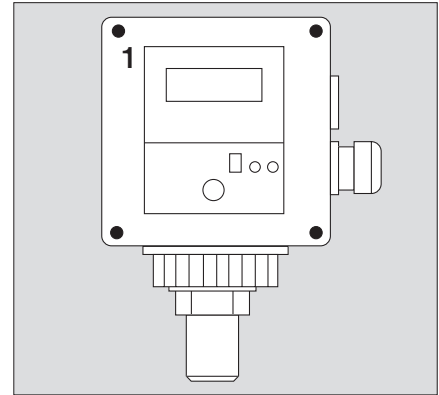

Transmitter Polytron Ex R

- Use only Dräger Sensors resp. sensing heads listed in the Order List page 25.
- If the sensing head is not to be replaced by a sensing head with the same sensor current or sensor voltage (see page 25), the procedure to be employed is described in the section entitled “Connection between transmitter Polytron Ex R and sensing head SE Ex”.
- The procedure outlined below may only be employed if sensor current resp. sensor voltage tally:
 - Loosen screws on top of sensing head and remove top section.
 - 1 Loosen sensor leads from terminals.
 - 2 Keep hold of the hexagon nut by means of a suitable tool and screw the sensor out of the nut.
 - 3 Remove old Ex-sensor from housing – fit new Ex-sensor
 - 2 Keep hold of the hexagon nut by means of a suitable tool and screw the sensor into the nut.
 - 1 Connect leads of Ex-sensor to terminals
 - brown to 1
 - yellow to 2
 - black to 3
 - Screw on top section.
- The sensor replacement can be carried out without interrupting supply voltage in explosion-hazard areas, since the sensor circuit is intrinsically safe.
- The transmitter must be calibrated following sensor replacement (see page 15).
- Allow 10 minutes for new Ex-sensor to warm up.

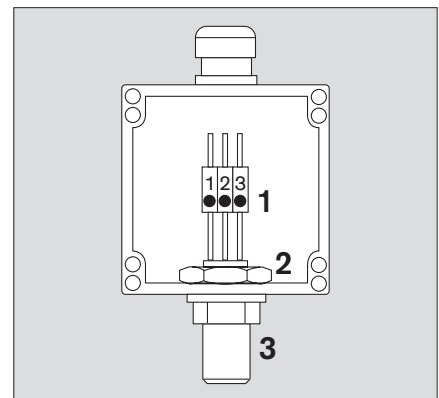

Fault – Cause – Remedy



Fault	Cause	Remedy
No Display	Cable faulty	Check cable to central controller.
Transmitter resp. sensing head can no longer be calibrated	Ex-sensor faulty or poisoned	Replace Ex-sensor, page 22.
Measurement current fluctuates with approx. 1 Hz between 2.5 mA and 5 mA	Sliding switch set to "1" = cal or "2" = test	Set sliding switch to "0" = normal.
Measurement current less than 3.0 mA	Sensor connection interrupted or Ex-sensor defective	Replace Ex-sensor, page 22.
	Measurement signal extremely negative	Calibrate transmitter resp. sensing head, page 15 or page 16.

Should it not be possible to eliminate the malfunctions occurring by employing the remedial measures described, or should other faults occur:

Transmitter resp. Sensing head SE Ex: check and, if necessary, arrange repair by trained service personnel.

Technical Data

Transmitter Polytron Ex and Ex R

Measuring range ¹⁾	0 to 99 %LEL (LEL: Lower Explosive Limit)	
Resolution of the digital display ¹⁾	1 % LEL, and 0.1 % LEL in calibration mode	
Measurement current	4 mA to 20 mA	
Operating voltage	10 V to 30 V	
Power consumption incl. Ex-sensor	≤2.5 W	
Cable gland	for cable diameters 7 to 12 mm	
Cable cross section per core	0.5 to 1.5 mm ²	
Dimensions and weight		
Transmitter Polytron Ex without Ex-sensor	approx. 125 x 140 x 100 mm W x H x D, approx. 1.5 kg (without cable gland)	
Transmitter Polytron Ex R	approx. 125 x 140 x 100 mm W x H x D, approx. 1.5 kg (without cable gland)	
Environmental conditions		
during operation	-40 °C to 65 °C ²⁾ 700 to 1300 hPa (in hazardous areas: 800 to 1100 hPa) 10 to 95 % r.h.	
during storage	-40 °C to 75 °C 700 to 1300 hPa 10 to 95 % r.h.	
CE marking	Electromagnetic Compatibility (directive 89/336/EEC), maximal fluctuation ≤3% LEL (methane/air)	
Degree of protection acc. to EN 50 029	IP 63	
Device description acc. to Directive 94/9/EC	Dräger Safety, D-23560 Lübeck, Germany Type Polytron Ex, Ex R	
Transmitter Polytron Ex	 II 2G EEx me [ib] IIC T4	-40 °C ≤ T _a ≤ 65 °C
Transmitter Polytron Ex R	 II 2G EEx me [ib] IIB T4	-40 °C ≤ T _a ≤ 65 °C
	BVS 03 ATEX E 160 X	
	CE ₀₁₅₈ , year of manufacturing by serial number ³⁾	

¹⁾ When using the Ex-sensor LC M resp. sensing head SE Ex LC M the reading has to be divided by ten.

²⁾ The readability of the LC-display might be affected at temperatures below -20 °C.

³⁾ The year of manufacturing is coded by the third capital letter of the serial number on the type plate:
S = 2002, T = 2003, U = 2004, W = 2005, X = 2006, Y = 2007, Z = 2008, A = 2009, B = 2010, C = 2011, etc.

Example:

Serial number: ARSH-0054, the 3rd capital letter is S, so the year of manufacturing is 2002.

Safety relevant parameters:

Power supply circuit (terminals K1, K2, K3 and K4): max. 32 V DC

Sensor output current circuit (terminals K11, K12 and K13):

Nominal voltage	max. 7.6 V DC
Current	max. 2350 mA
Power	max. 3.23 W
Max. connectable inductivity L_0 :	3 μ H
Max. connectable capacity C_0 :	342 nF

Ex-sensors

Ex-sensor PR M

Part number 68 09 225

Dimensions and weight approx. dia.50 mm x 60 mm, approx. 0.2 kg

Operational parameters

Constant current, sensor current:	270 mA
Voltage at test points	891 mV

Device description acc. to Directive 94/9/EC

Dräger Safety, D-23560 Lübeck, Germany
 Type Ex-sensor PR M
 II 2G EEx d IIC T6/T5/T4/T3
 DMT 97 ATEX E001X
 CE₀₁₅₈, year of manufacturing by serial number ¹⁾

Ex-sensor LC M

Part number 68 10 350

Dimensions and weight approx. dia.50 mm x 60 mm, approx. 0.2 kg

Operational parameters



Constant current, sensor current:	276 mA
Voltage at test points	911 mV

Device description acc. to Directive 94/9/EC

Dräger Safety, D-23560 Lübeck, Germany
 Type Ex-sensor LC M
 II 2G EEx d IIC T6/T5/T4/T3
 DMT 02 ATEX E 188X
 CE₀₁₅₈, year of manufacturing by serial number ¹⁾

¹⁾ The year of manufacturing is coded by the third capital letter of the serial number on the type plate:
 S = 2002, T = 2003, U = 2004, W = 2005, X = 2006, Y = 2007, Z = 2008, A = 2009, B = 2010, C = 2011, etc.
 Example:
 Serial number: ARSH-0054, the 3rd capital letter is S, so the year of manufacturing is 2002.

Sensing Heads SE Ex

Sensing head SE Ex PR M	
Part number	68 09 758
Operational parameters	
Constant current, sensor current:	270 mA
Voltage at test points	891 mV
Device description acc. to Directive 94/9/EC	<p>Dräger Safety, D-23560 Lübeck, Germany Type SE Ex PR M ET  II 2G EEx de IIC T4/T5/T6 DMT 97 ATEX E 006X CE₀₁₅₈, year of manufacturing by serial number ¹⁾</p>
Sensing head SE Ex LC M	
Part number	68 10 486
Operational parameters	
Constant current, sensor current:	276 mA
Voltage at test points	911 mV
Device description acc. to Directive 94/9/EC	<p>Dräger Safety, D-23560 Lübeck, Germany Type SE Ex LC M  II 2G EEx de IIC T4/T5/T6 DMT 97 ATEX E 006X CE₀₁₅₈, year of manufacturing by serial number ¹⁾</p>

¹⁾ The year of manufacturing is coded by the third capital letter of the serial number on the type plate:
 S = 2002, T = 2003, U = 2004, W = 2005, X = 2006, Y = 2007, Z = 2008, A = 2009, B = 2010, C = 2011, etc.
 Example:
 Serial number: ARSH-0054, the 3rd capital letter is S, so the year of manufacturing is 2002.

Dimensions

- Transmitter Ex / Ex R, page 28
- Sensing Head SE Ex, page 29

Measuring other gases and vapours

The transmitter Polytron Ex (83 17 517) with Ex-sensor PR M (68 09 225) has been tested for suitability for detecting the following gases and vapours in accordance with standards EN 50 054 and EN 50 057:

Gas or vapour	Chemical symbol	LEL in % V/V	Linearity error up to 70 % LEL in % LEL	Test gas concentration Propane in % V/V	Display when propane is applied ¹⁾ in % LEL
Acetone	CH ₃ COCH ₃	2.2	≤ 3	0.99	65 ... 69
Acetylene	C ₂ H ₂	1.5	≤ 4	0.49	50 ... 65 ²⁾
Ammonia	NH ₃	15.0	≤ 6	0.51	19 ... 24 ²⁾
Gasoline 065/095	HC mixture	1.1	≤ 4	0.51	40 ... 45
Benzene	C ₆ H ₆	1.2	≤ 3	0.51	40 ... 61
1,3-butadiene	CH ₂ =CH-CH=CH ₂	1.4	≤ 11	0.51	37 ... 51
2-butanone (MEK)	CH ₃ COC ₂ H ₅	1.8	≤ 4	0.51	39 ... 42
n-butane	C ₄ H ₁₀	1.5	≤ 3		²⁾
n-butyl acetate	CH ₃ COOC ₄ H ₁₀	1.2	≤ 4	0.51	50 ... 55
Cyclopropane	C ₃ H ₆	2.4	≤ 5	0.99	44 ... 55
Diethylether	C ₂ H ₅ OC ₂ H ₅	1.7	≤ 3	0.51	37 ... 43
Dimethylether	CH ₃ OCH ₃	3.0	≤ 4		²⁾
Ethanol	C ₂ H ₅ OH	3.3	≤ 4	0.99	51 ... 55
Ethene (ethylene)	C ₂ H ₄	2.7	≤ 5		²⁾
Ethyl acetate	CH ₃ COOC ₂ H ₅	2.1	≤ 4	0.99	67 ... 72
Ethylene oxide	C ₂ H ₄ O	2.6	≤ 3	0.51	36 ... 41 ²⁾
n-hexane	C ₆ H ₁₄	1.2	≤ 4	0.99	67 ... 76
Methane	CH ₄	5.0	≤ 3		²⁾
Methanol	CH ₃ OH	5.5	≤ 4	0.99	49 ... 53
n-nonane	C ₉ H ₂₀	0.7	≤ 3 ³⁾	0.51	57 ... 58
n-octane	C ₈ H ₁₈	0.8	≤ 4	0.51	51 ... 60
n-pentane	C ₅ H ₁₂	1.4	≤ 3	1.05	67 ... 68
i-propanol	(CH ₃) ₂ CHOH	2.0	≤ 4	0.51	37 ... 40
Propane	C ₃ H ₈	2.0	≤ 4		²⁾
Propylene oxide	C ₃ H ₆ O	1.9	≤ 6	0.49	41 ... 44
Propene (propylene)	C ₃ H ₆	2.0	≤ 4	0.51	30 ... 44 ²⁾
Toluene	C ₆ H ₅ CH ₃	1.2	≤ 3	0.51	38 ... 57
Hydrogen	H ₂	4.0	≤ 6 ⁴⁾		²⁾

¹⁾ These figures apply to new-value sensors. Dispersion and in particular changes in the sensor due to age can lead to deviations in the values displayed.

²⁾ Test gases with approx. 50 % LEL of the respective substance are available for these substances. In principle, adjustment using a specific test gas will rule out a measuring error due to sensor sensitivity dispersion.

³⁾ Up to 60 % LEL. The calibration curve could only be plotted up to 60 % LEL due to the low vapour pressure of the substance.

⁴⁾ Up to 50 % LEL: ≤ 2 % LEL

Notes on Table

Column 3: The lower explosion limits (LEL) shown were mostly taken from Annex A to EN 50054:1998. Different lower explosion limits may apply when setting up the devices at the place of use.

Column 4: In the case of the Polytron Ex calibrated to the substance shown (in column 1), the display in the 0 to 70 % LEL range varies from the actual concentration of the substance by not more than the value indicated here.

Column 5: Concentration of the reference gas (propane) in air

Column 6: Application of propane at the concentration shown (in column 5) leads to the display indicated here for the Polytron Ex transmitter calibrated to the substance shown (in column 1).

Example: Polytron Ex, calibrated to benzene, display when 0.51 % by vol. propane is applied: 40 to 61 % LEL.

Transmitter Ex / Ex R

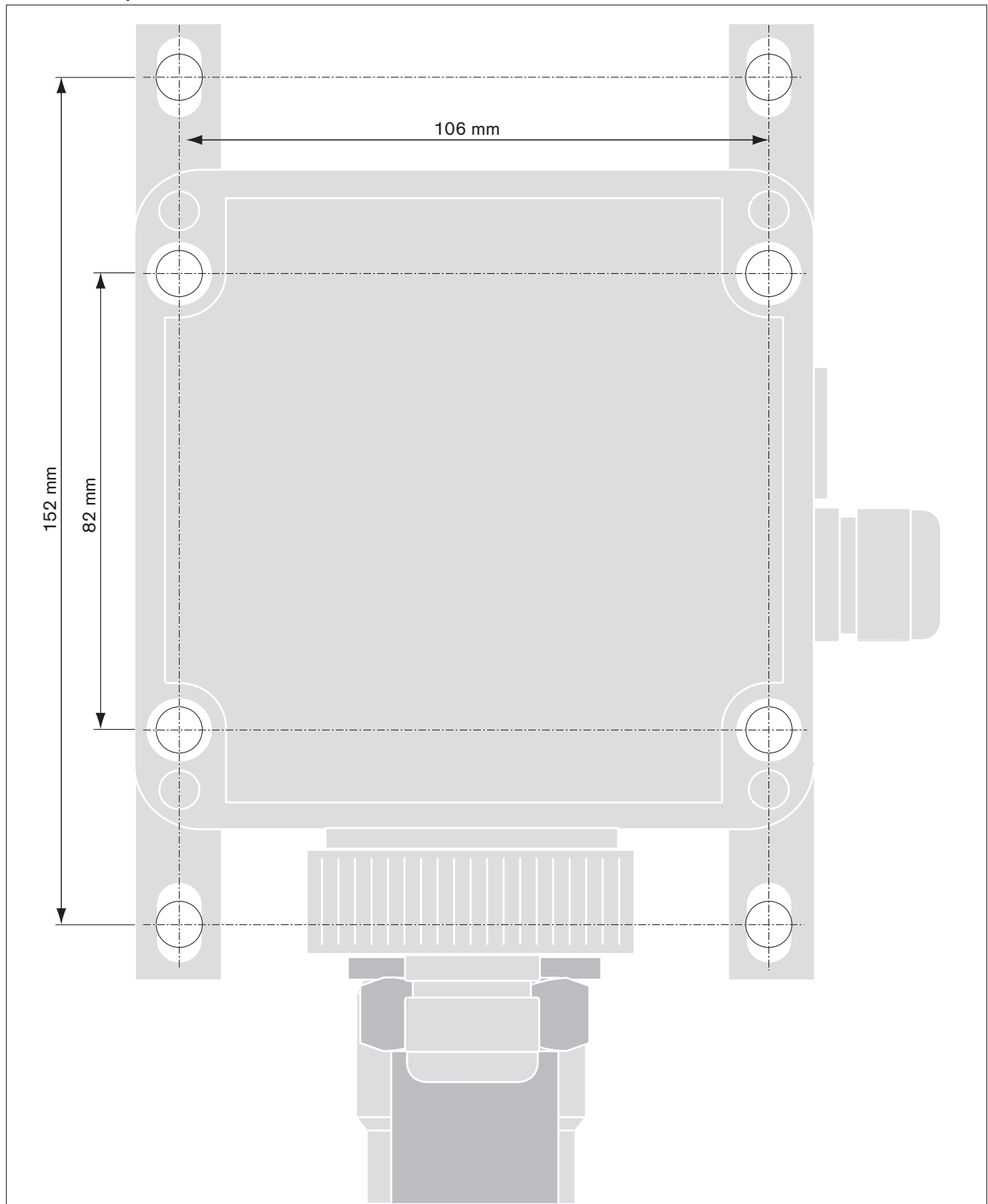

9023744_1.rpt

Sensing Head SE Ex

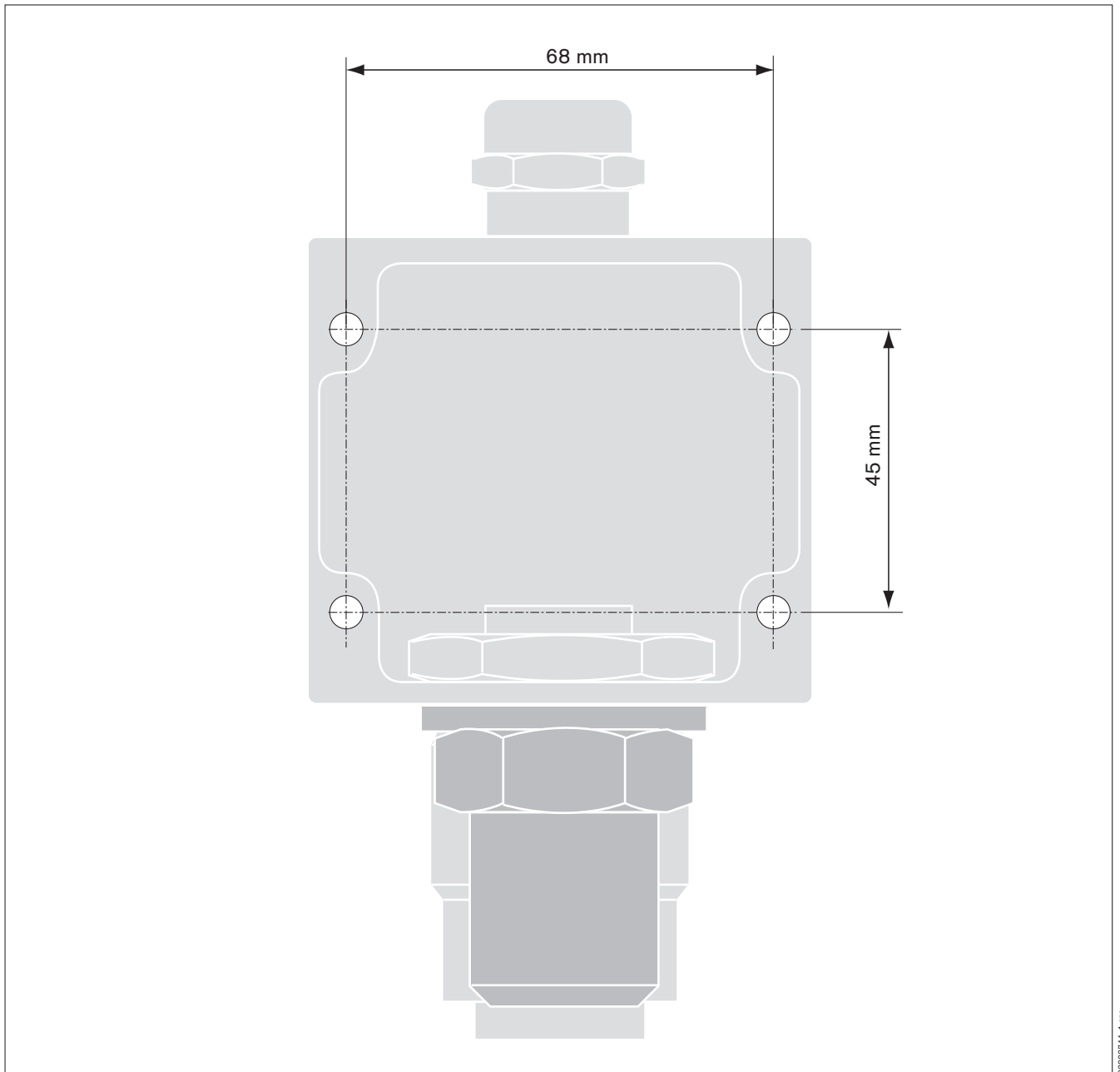

09023744_1.eps

Design and Mode of Operation

The transmitter Polytron Ex consists of a housing, an Ex-sensor and the corresponding electronics.

The transmitter Polytron Ex R consists of a housing with electronics and a sensing head including an Ex-sensor, installed at a maximum distance of 10 m.

The housing made of conductive plastic prevents electrostatic charge-up and is resistant to solvents.

The Ex-sensor is a transducer for measuring the partial pressure of flammable gases and vapours present in the atmosphere. They use the heat-of-reaction principle. The monitored air is diffusing through the sintered metal disc into the Ex-sensor. This is where the mixture of flammable gases and vapours are catalytically combusted at a heated detector element (pellistor).

The oxygen required for combustion is obtained from the monitored air. The detector element is additionally heated by the resultant heat of reaction. This heat in turn causes a change in the resistance of the detector element, which is proportional to the concentration of the flammable gas or vapour.

In addition to the catalytically active detector element, the Ex-sensor accommodates an inactive compensator element, which is likewise heated. Both elements are parts of a Wheatstone bridge. Environmental effects such as temperature, humidity or heat conductivity of the ambient air to be monitored, have identical effects on the two elements, whereby these effects on the measuring signal are almost completely compensated.

The sensor signal is amplified by the electronics, indicated on the display and converted into a 4 to 20 mA signal which is passed to the central controller.

Principle of Operation

- 1 Measuring chamber
- 2 Detector element
- 3 Sintered metal
- 4 Compensator element

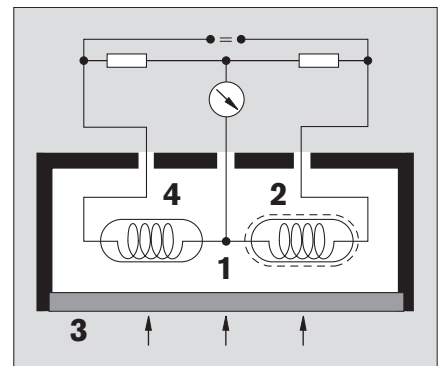

Order List

Name and Description	Order-Nr.
Transmitter Polytron Ex without Ex-sensor	83 17 517
Ex-sensor PR M ¹⁾ (measuring range 0 to 99 %LEL)	68 09 225
Ex-sensor LC M ¹⁾ (measuring range 0 to 9.9 %LEL)	68 10 350
Transmitter Polytron Ex R with 10 m sensor cable	83 17 509
Sensing head SE Ex PR M ET (measuring range 0 to 99 %LEL)	68 09 758
Sensing head SE Ex LC M (measuring range 0 to 9.9 %LEL)	68 10 486
Accessories	
Cable gland (7 to 12 mm) for second connecting cable	83 16 563
Dust filter ²⁾ (packing qty. 10)	68 10 537
Calibration Accessories	
Calibration adapter	68 06 978
Test gas cylinder	on request
Pressure reduce for test gas cylinder	on request
Calibration chamber ²⁾	68 02 206
Spare Parts	
Ex-sensor PR M	68 09 225
Ex-sensor LC M	68 10 350
Adapter plate	68 10 284
Special key for opening flap for adjusting elements (comprised in scope of delivery)	12 83 820
Earthing kit to connect the transmitter to a potential earth externally	83 15 609

¹⁾ Parts have an unlimited shelf life. This also applies to sensors if stored in their original packaging under the conditions specified on page 24.

²⁾ Not tested in the 1st supplement to the EC type test certificate BVS 03 ATEX E 160 X.

EC Type-Examination Certificate BVS 03 ATEX E 160 X



- (1) **EG-Baumusterprüfbescheinigung**
- (2) **- Richtlinie 94/9/EG -
Geräte und Schutzsysteme zur bestimmungsgemäßen Verwendung
in explosionsgefährdeten Bereichen**
- (3) **BVS 03 ATEX E 160 X**
- (4) **Gerät: Gasmessgerät Typ Polytron Ex und Ex R**
- (5) **Hersteller: Dräger Safety AG & Co. KGaA**
- (6) **Anschrift: D - 23560 Lübeck**
- (7) Die Bauart dieses Gerätes sowie die verschiedenen zulässigen Ausführungen sind in der Anlage zu dieser Baumusterprüfbescheinigung festgelegt.
- (8) Die Zertifizierungsstelle der EXAM BBG Prüf- und Zertifizier GmbH, benannte Stelle Nr. 0158 gemäß Artikel 9 der Richtlinie 94/9/EG des Europäischen Parlaments und des Rates vom 23. März 1994, bescheinigt, dass das Gerät die grundlegenden Sicherheits- und Gesundheitsanforderungen für die Konzeption und den Bau von Geräten und Schutzsystemen zur bestimmungsgemäßen Verwendung in explosionsgefährdeten Bereichen gemäß Anhang II der Richtlinie erfüllt.
Die Ergebnisse der Prüfung sind in dem Prüfprotokoll BVS PP 03.2128 EG niedergelegt.
- (9) Die grundlegenden Sicherheits- und Gesundheitsanforderungen werden erfüllt durch Übereinstimmung mit
- | | |
|---------------------|-------------------------|
| EN 50014:1997+A1-A2 | Allgemeine Bestimmungen |
| EN 50019:2000 | Erhöhte Sicherheit |
| EN 50020:1994 | Eigensicherheit |
| EN 50028:1987 | Vergusskapselung |
- (10) Falls das Zeichen „X“ hinter der Bescheinigungsnummer steht, wird in der Anlage zu dieser Bescheinigung auf besondere Bedingungen für die sichere Anwendung des Gerätes hingewiesen.
- (11) Diese EG-Baumusterprüfbescheinigung bezieht sich nur auf die Konzeption und die Baumusterprüfung des beschriebenen Gerätes in Übereinstimmung mit der Richtlinie 94/9/EG.
Für Herstellung und Inverkehrbringen des Gerätes sind weitere Anforderungen der Richtlinie zu erfüllen, die nicht durch diese Bescheinigung abgedeckt sind.
- (12) Die Kennzeichnung des Gerätes muss die folgenden Angaben enthalten:

II 2G EEx me [ib] IIC bzw. IIB T4

EXAM BBG Prüf- und Zertifizier GmbH

Essen, den 25. Juni 2003

DMT-Zertifizierungsstelle

Fachbereichsleiter

Seite 1 von 2 zu BVS 03 ATEX E 160 X
Dieses Zertifikat darf nur unverändert weiterverbreitet werden.
Dinnendahlstrasse 9 44809 Bochum Telefon-Phone 0201/172-3947 Telefax-Fax 0201/172-3948
(bis 31.05.2003: Deutsche Montan Technologie GmbH, Am Technologiepark 1, 45307 Essen)



(13) Anlage zur

(14) **EG-Baumusterprüfbescheinigung**
BVS 03 ATEX E 160 X

(15) 15.1 Gegenstand und Typ

Gasmessgerät Typ Polytron Ex und Ex R

15.2 Beschreibung

Der Gasmesskopf Typ Polytron Ex dient in Verbindung mit einem an den eigensicheren Ausgangsanschlussklemmen K11, K12 und K13 anzuschließenden Sensor zur Messung von brennbaren Gasen und Dämpfen unter atmosphärischen Bedingungen.

Der Anschluss des Gasmesskopfs Typ Polytron Ex R erfolgt über eine mit ihm fest verbundene Leitung, die eine Länge bis zu 10 m haben kann.

Die nichteigensichere Stromversorgung und Signalübertragung (Stromschleife 4 – 20 mA) erfolgt wahlweise über eine Dreidraht- oder zwei Zweidraht-Leitungen, die in einem in der Zündschutzart Erhöhte Sicherheit „e“ ausgeführten Klemmenraum über die Klemmen K1, K2, K3 und K4 angeschlossen werden. Der Messwert wird zusätzlich von einem LC-Display angezeigt.

Das Gerät, das in eigensicheren Anlagen als Zubehör verwendet wird, enthält nur Bauteile, die die Zündschutzart Eigensicherheit nicht beeinträchtigen.

15.3 Kenngrößen

15.3.1 Nichteigensicherer Versorgungsstromkreis und Signalstromkreis
(Klemmen K1, K2, K3 und K4)

Nennspannung			DC 24	V
Maximale Eingangsspannung	Um		AC 250	V

15.3.2 Eigensicherer Ausgangstromkreis
(Klemmen K11, K12 und K13 bzw. Anschlussleitung)

Maximale Ausgangsspannung	Uo		7,6	V
Maximaler Ausgangstrom	Io		3,35	A
Maximale Ausgangsleistung	Po		3,23	W
Maximale äußere Kapazität	Co		342	nF
Maximale äußere Induktivität	Lo		3	µH

(16) Prüfprotokoll

BVS PP 030.2128 EG, Stand 25.06.2003

(17) Besondere Bedingungen für die sichere Anwendung

An die Anschlussklemmen K11, K12 und K13 des Gasmessgeräts Typ Polytron Ex bzw. an die Anschlussleitung des Gasmessgeräts Typ Polytron Ex R darf nur ein gesondert bescheinigter Sensor angeschlossen werden. Der Einbau hat so zu erfolgen, dass mindestens die Schutzart IP20 gemäß EN 60529 erhalten bleibt.

Die Messfunktion für den Explosionsschutz gemäß EN 50054 und EN 50057 ist nicht Gegenstand dieser EG-Baumusterprüfbescheinigung.



1. Nachtrag

(Ergänzung gemäß Richtlinie 94/9/EG Anhang III Ziffer 6)

zur EG-Baumusterprüfbescheinigung BVS 03 ATEX E 160 X

Gerät: Gasmessgerät Typ Polytron Ex und Ex R

Hersteller: Dräger Safety AG & Co. KGaA

Anschrift: D - 23560 Lübeck

Beschreibung

Die grundlegenden Sicherheits- und Gesundheitsanforderungen hinsichtlich der Messfunktion für den Explosionsschutz werden erfüllt durch Anwendung von

EN 50054:1998
EN 50057:1998
EN 50271:2001

Dieser Nachtrag zur EG-Baumusterprüfbescheinigung gilt für Geräte des Typs Polytron Ex.

Dieser Nachtrag zur EG-Baumusterprüfbescheinigung umfasst die Messfunktion für die folgenden Gase und Dämpfe im Messbereich 0 - 99 % UEG:

Methan, Propan, Wasserstoff, n-Butan, Ethen, Dimethylether, Aceton, Ammoniak, Benzin 065/095, Benzol, 1,3-Butadien, Cyclopropan, Diethylether, Essigsäure-n-butylester, Ethanol, Ethylacetat, Ethylenoxid, n-Hexan, Methanol, Methylethylketon, n-Nonan, n-Octan, 2-Propanol, Propen, Toluol, Acetylen, Propylenoxid und n-Pentan

Prüfbericht

EG-Baumusterprüfbescheinigung BVS 03 ATEX E 160 X vom 25.06.2003
EG-Baumusterprüfbescheinigung DMT 97 ATEX E 001 X vom 21.03.1997
PFG-Nr. 41300199P vom 24.08.1999
PFG-Nr. 41300199P NII vom 20.12.1999
PFG-Nr. 41300199P NIII vom 05.09.2000
PFG-Nr. 41300104P vom 30.04.2004



Besondere Bedingungen für die sichere Anwendung

- Die Angaben der Betriebsanleitung im Abschnitt "Angaben zur sicheren Verwendung" sind zu beachten.

EXAM BBG Prüf- und Zertifizier GmbH

Bochum, den 30.04.2004



Zertifizierungsstelle



Fachbereich

Declaration of Conformity



Konformitätserklärung Declaration of Conformity

Wir / We Dräger Safety AG & Co. KGaA
Revalstraße 1
D-23560 Lübeck
Deutschland / Germany

erklären, dass das Produkt / declare that the product

Gasmessgerät Typ Polytron Ex / Ex R
Gas Detection Instrument type Polytron Ex / Ex R

gemäß den Bestimmungen der Richtlinie 94/9/EG (Geräte und Schutzsysteme zur bestimmungsgemäßen Verwendung in explosionsgefährdeten Bereichen) übereinstimmt mit dem Baumuster der EG-Baumusterprüfbescheinigung

following the provisions of Directive 94/9/EC (Equipment and protective systems intended for use in potentially explosive atmospheres) is in conformity with the type of the EC-type-examination certificate

BVS 03 ATEX E 160 X

für / for Gerätegruppe und -kategorie / Equipment Group and Category: **II 2G**
Zündschutzart / Type of Protection: **me[ib]**
Explosionsgruppe / Explosion Group: **IIC / IIB**
Temperaturklasse / Temperature Class: **T4**

ausgestellt von der benannten Stelle / issued by the notified body

EXAM – BBG Prüf- und Zertifizier GmbH
Dinnendahlstraße 9
D-44809 Bochum
Kennnummer / identification number 0158.

Das Produkt wurde unter einem Qualitätssicherungssystem hergestellt, endabgenommen und geprüft, das zugelassen wurde von der benannten Stelle

The product has been manufactured, finally inspected and tested under a quality system which has been approved by the notified body

DMT - Gesellschaft für Forschung und Prüfung mbH
Zertifizierungsstelle
Am Technologiepark 1
D-45307 Essen
Kennnummer / identification number 0158.

Ralf Drews
Gasmesstechnologie Entwicklung
Dräger Safety AG & Co. KGaA

Lübeck, 19.08.2003

A handwritten signature in black ink, appearing to read "Ralf Drews".

Dokument-Nr. / document no.: SE20051 "01"
Seite 1 von 1 / page 1 of 1

Index

3-Wire Connection	11
4-Wire Connection	12
Accessories	31
Adjustment of Constant Current	14
Areas subject to explosion hazards	4
Cable cross section	24
Cable gland	11, 12, 24
Cable resistance	11, 12
Calibrating Transmitter Polytron Ex	15
Calibrating Transmitter Polytron Ex R	16
Calibration Accessories	31
Calibration adapter	15
Calibration chamber	16, 17
Calibration gas concentration	15, 17, 18
Catalyst poisons	8
CE marking	24
Central controller	5
Completion of Calibration	16, 17
Completion of Test	19
Connection between Transmitter and Central Unit	11
Connection cable	10
Constant current	14
Declaration of Conformity	36
Degree of protection	24
Density of gas	9
Design	30
Device Concept	6
Device description	24, 25, 26
Dimensions	24, 25, 26
EC Type-Examination Certificate	32
Environmental conditions	24
Ex-factory-setting	14
Explosion protection	8
Ex-sensor	13
Ex-sensor Replacement	22
Ex-sensor warm up time	22
Faults	23
Full scale value	15, 17, 18
Hints for Safe Use	7

Inhibition of alarms	5
Installation location	9
Installing Electrical Connections	11
Installing Ex-sensor in the Transmitter	13
Installing Transmitters	9
Intended Use	5
Interruptions in Operation	20
Intrinsic Safety Concept	8
Liability	4
Maintenance	4, 21
Measurement current	24
Measuring range	5, 24
Mode of Operation	30
Mounting	9
Mounting brackets	9, 10
One-man-calibration	5
Operating voltage	24
Operational parameters	25, 26
Operational Use	20
Order List	31
Power consumption	24
Power supply circuit	25
Principle of Operation	30
Resolution	24
Safety	4
Safety relevant parameters	25
Screen	11
Sensing head SE Ex LC M	5
Sensing head SE Ex PR M	5
Sensitivity Adjustment	15, 17
Sensor output current circuit	25
Solvent vapours	16, 17
Spare Parts	31
Start-Up	15
Technical Data	24
Test gas	15, 17
Testing the Constantly Amplified Sensor Signal	18
Transmitter	8
Transmitter Polytron Ex with Ex-sensor LC M	6
Transmitter Polytron Ex with Ex-sensor PR M	6

Transmitter Polytron Ex R with sensing head SE Ex LC M	6
Transmitter Polytron Ex R with sensing head SE Ex PR M ET	6
Transmitter with measurement function for explosion protection according to 94/9/EC	8
Ventilation	9
Vorbeugender Explosionsschutz	8
Weight	24, 25
Zero Adjustment	15, 16
Zero gas	15, 16

www.norrscope.com