

# Diaphragm Valve, Metal

## Construction

The GEMÜ 615 2/2-way diaphragm valve has a low maintenance piston actuator which can be controlled by inert gases. Normally Closed, Normally Open and Double Acting control functions are available. An optical position indicator is integrated as standard.

## Features

- Suitable for inert and corrosive\* liquid and gaseous media
- Insensitive to particulate media
- Valve body and diaphragm available in various materials and designs
- Compact design (ideal when space is at a premium)
- Versions according to ATEX on request

## Advantages

- Hermetic separation between medium and actuator
- Optional flow direction
- Installation for an optimized draining is possible
- Optional accessories:
  - Stroke limiter
  - Electrical position indicators with microswitches or proximity switches

\*see information on working medium on page 2



Sectional drawing

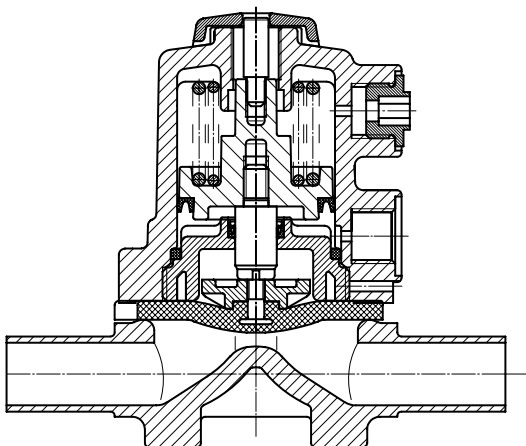

## Technical data

### Working medium

Corrosive, inert, gaseous and liquid media which have no negative impact on the physical and chemical properties of the body and diaphragm material.

### Temperatures

<b>Media temperature</b>	-10 ... 80 °C
<b>Ambient temperature</b>	0 ... 60 °C

### Control medium

#### Inert gases

**Max. perm. temperature of control medium** 40 °C

**Filling volume** 0.02 dm<sup>3</sup>

Diaphragm size	Operating pressure [bar]		Control pressure [bar]		
	EPDM/FPM	PTFE	C.f. 1	C.f. 2	C.f. 3
10	0 - 6	0 - 6	5 - 7	max. 5.5	max. 5.0

All pressures are gauge pressures. Operating pressure values were determined with static operating pressure applied on one side of a closed valve. Sealing at the valve seat and atmospheric sealing is ensured for the given values.

Information on operating pressures applied on both sides and for high purity media on request.

### Kv values [m<sup>3</sup>/h]

Pipe standard	DIN	EN 10357 series B (formerly DIN 11850 series 1)	EN 10357 series A (formerly DIN 11850 series 2) / DIN 11866 series A	DIN 11850 Series 3	SMS 3008	ASME BPE / DIN 11866 series C	ISO 1127 / EN 10357 series C / DIN 11866 series B	
								Connection code
<b>MG</b>	<b>DN</b>							
10	10	-	2.4	2.4	2.4	-	2.2	3.3
	15	3.3	3.8	3.8	3.8	-	2.2	4.0
	20	-	-	-	-	-	3.8	-

MG = diaphragm size

Kv values determined acc. to DIN EN 60534, inlet pressure 5 bar, Δp 1 bar, stainless steel valve body (forged body) and soft elastomer diaphragm. The Kv values for other product configurations (e.g. other diaphragm or body materials) may differ. In general, all diaphragms are subject to the influences of pressure, temperature, the process and their tightening torques. Therefore the Kv values may exceed the tolerance limits of the standard.

## Technical data

### Control pressure / operating pressure diagram

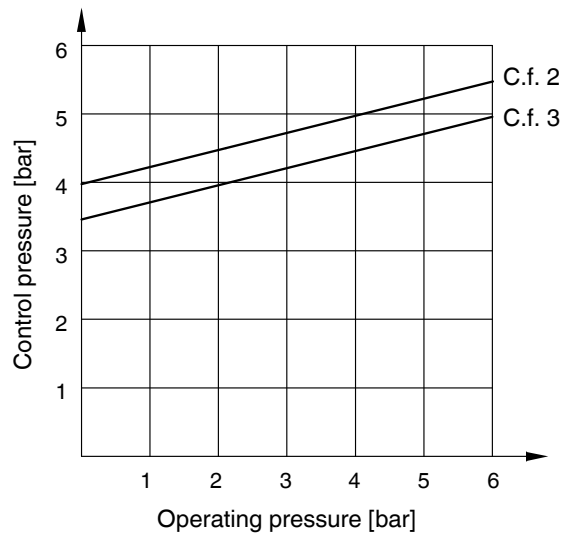

The control pressure depending on the prevailing operating pressure, as shown in the diagram, is intended as a guide for operating the system with low wear on the diaphragm.

## Order data

Body configuration	Code
2/2-way body	D

Connection	Code
<b>Butt weld spigots</b>	
Spigots DIN	0
Spigots EN 10357 series B (formerly DIN 11850 series 1)	16
Spigot EN 10357 series A (formerly DIN 11850 series 2) / DIN 11866 series A	17
Spigots DIN 11850 series 3	18
Spigots JIS-G 3459	36
Spigots BS 4825 Part 1	55
Spigot ASME BPE / DIN 11866 series C	59
Spigot ISO 1127 / EN 10357 series C / DIN 11866 series B	60
Spigots ANSI/ASME B36.19M Schedule 10s	63
Spigots ANSI/ASME B36.19M Schedule 40s	65

<b>Threaded connections</b>	
Threaded sockets DIN ISO 228	1
Threaded spigots DIN 11851	6
One side threaded spigot, other side cone spigot and union nut, DIN 11851	62
Aseptic unions on request	

<b>Clamp connections</b>	
Clamps ASME BPE for pipe ASME BPE, length ASME BPE	80
Clamp DIN 32676 series B for pipe EN ISO 1127, length EN 558, series 7	82
Clamp ASME BPE for pipe ASME BPE, length EN 558, series 7	88
Clamps DIN 32676 series A for pipe DIN 11850, length EN 558, series 7	8A

For overview of available valve bodies for GEMÜ 615 see page 9

Valve body material	Code
CW617N (Brass)	12
1.4435, investment casting	C3
1.4408, investment casting	37
1.4435 (316 L), forged body	40
1.4435 (BN2), forged body Fe<0.5%	42
1.4539, forged body	F4

Diaphragm material	Code
FPM	4
EPDM	13
EPDM	14
EPDM	17
PTFE/EPDM, one-piece	54
PTFE/EPDM, two-piece	5M
Material complies with FDA requirements, except code 4 and 14	

Control function	Code
Normally closed (NC)	1
Normally open (NO)	2
Double acting (DA)	3

Actuator size	Code
Standard version	1/N

Surface finish	Code
Code see page 5	

Order example	615	15	D	60	C3	17	1	1/N	1500
Type	615								
Nominal size		15							
Body configuration (code)			D						
Connection (code)				60					
Valve body material (code)					C3				
Diaphragm material (code)						17			
Control function (code)							1		
Actuator size (code)								1/N	
Surface finish (code see page 5)									1500

## Order data

### Internal surface finishes for forged and block material bodies <sup>1</sup>

Readings for Process Contact Surfaces	Mechanically polished <sup>2</sup>		Electropolished	
	Hygienic class DIN 11866	Code	Hygienic class DIN 11866	Code
Ra ≤ 0.80 µm	H3	1502	HE3	1503
Ra ≤ 0.60 µm	-	1507	-	1508
Ra ≤ 0.40 µm	H4	1536	HE4	1537
Ra ≤ 0.25 µm <sup>3</sup>	H5	1527	HE5	1516

Readings for Process Contact Surfaces acc. to ASME BPE 2016 <sup>4</sup>	Mechanically polished <sup>2</sup>		Electropolished	
	ASME BPE Surface Designation	Code	ASME BPE Surface Designation	Code
Ra Max. = 0.76 µm (30 µinch)	SF3	SF3	-	-
Ra Max. = 0.64 µm (25 µinch)	SF2	SF2	SF6	SF6
Ra Max. = 0.51 µm (20 µinch)	SF1	SF1	SF5	SF5
Ra Max. = 0.38 µm (15 µinch)	-	-	SF4	SF4

### Internal surface finishes for investment cast bodies

Readings for Process Contact Surfaces	Mechanically polished <sup>2</sup>	
	Hygienic class DIN 11866	Code
Ra ≤ 6.30 µm	-	1500
Ra ≤ 0.80 µm	H3	1502
Ra ≤ 0.60 µm <sup>5</sup>	-	1507

<sup>1</sup> Surface finishes of customized valve bodies may be limited in special cases.

<sup>2</sup> Or any other finishing method that meets the Ra value (acc. to ASME BPE).

<sup>3</sup> The smallest possible Ra finish for pipe connections with an internal pipe diameter < 6 mm is 0.38 µm.

<sup>4</sup> When using these surfaces, the bodies are marked according to the specifications of ASME BPE.

The surfaces are only available for valve bodies which are made of materials (e.g. GEMÜ material codes 40, 41, F4, 44) and use connections (e.g. GEMÜ connection codes 59, 80, 88) according to ASME BPE.

<sup>5</sup> Not possible for GEMÜ connection code 59, DN 8 and GEMÜ connection code 0, DN 4.

Ra acc. to DIN EN ISO 4288 and ASME B46.1

## Dimensions [mm]

### Actuator dimensions

Diaphragm size	A	A1	A2	Ø B	B1	B2	G	Weight [kg]
10	80	21	30	57	35	68	G 1/4	0.18

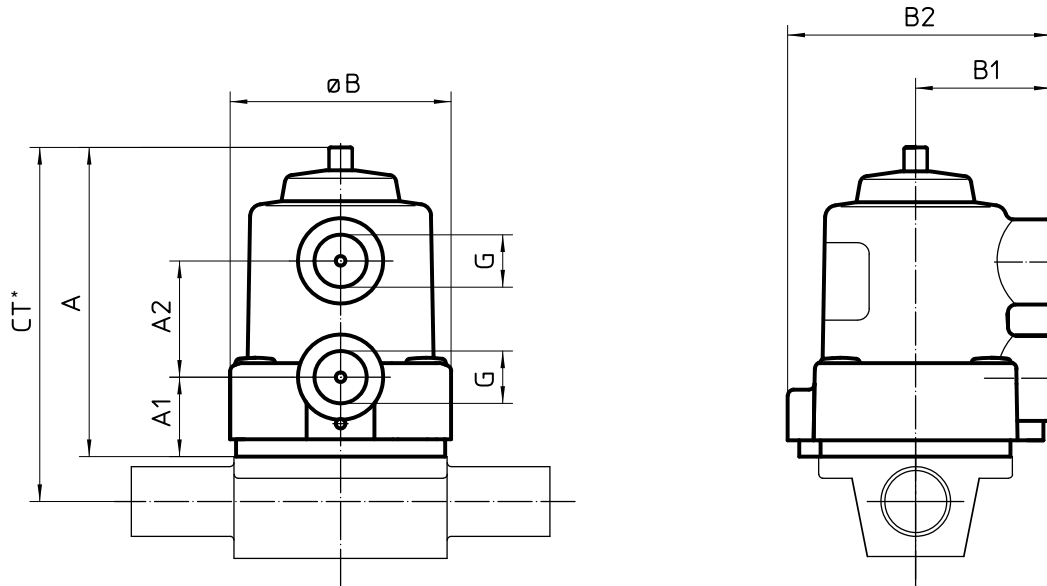

\*  $CT = A + H1$  (see body dimensions)

## Body dimensions [mm]

### Butt weld spigots, connection code 0, 16, 17, 18, 60 Valve body material: Investment casting (code C3), forged body (code 40, F4)

Pipe standard						DIN		EN 10357 series B (formerly DIN 11850 series 1)		EN 10357 series A (formerly DIN 11850 series 2) / DIN 11866 series A		DIN 11850 Series 3		ISO 1127 / EN 10357 series C / DIN 11866 series B		Weight [kg]
Connection code						0		16		17		18		60		
MG	DN	NPS	L	c	H1	ød	s	ød	s	ød	s	ød	s	ød	s	
10	10	3/8"	108	25	12.5	-	-	12	1.0	13	1.5	14	2.0	17.2	1.6	0.30
	15	1/2"	108	25	12.5	18	1.5	18	1.0	19	1.5	20	2.0	21.3	1.6	0.30

\* only for investment cast design      MG = diaphragm size  
For materials see overview on page 9

### Butt weld spigots, connection code 36, 55, 59, 63, 65 Valve body material: Investment casting (code C3), forged body (code 40, F4)

Pipe standard							JIS-G 3459		BS 4825 Part 1		ASME BPE / DIN 11866 series C		ANSI/ASME B36.19M Schedule 10s		ANSI/ASME B36.19M Schedule 40s		Weight [kg]
Connection code							36		55		59		63		65		
MG	DN	NPS	L	c	H1*	H1**	ød	s	ød	s	ød	s	ød	s	ød	s	
10	10	3/8"	108	25	-	12.5	17.3	1.65	9.53	1.2	9.53	0.89	17.1	1.65	17.1	2.31	0.30
	15	1/2"	108	25	-	12.5	21.7	2.10	12.70	1.2	12.70	1.65	21.3	2.11	21.3	2.77	0.30
	20	3/4"	108	25	12.5	12.5	-	-	19.05	1.2	19.05	1.65	-	-	-	-	0.30

\* only for investment cast design      \*\* only for forged design      MG = diaphragm size  
For materials see overview on page 9

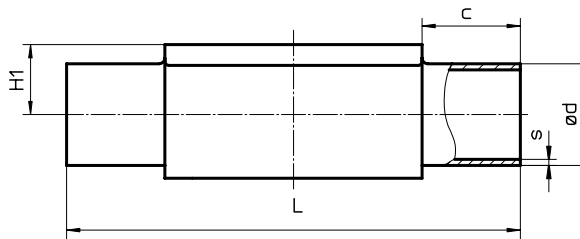

## Body dimensions [mm]

### Threaded sockets, connection code 1 Valve body material: brass (code 12), investment casting (code 37)

MG	DN	R	Material code 12						Material code 37						Weight [kg]
			H	H1	t	L	SW2	Number of flats	H	H1	t	L	SW2	Number of flats	
10	12	G 3/8	23	11	13	55	22	2	25	13	12	55	22	2	0.17
	15	G 1/2	29	14	15	75	25	2	30	15	15	68	27	2	0.26

MG = diaphragm size

For materials see overview on page 9

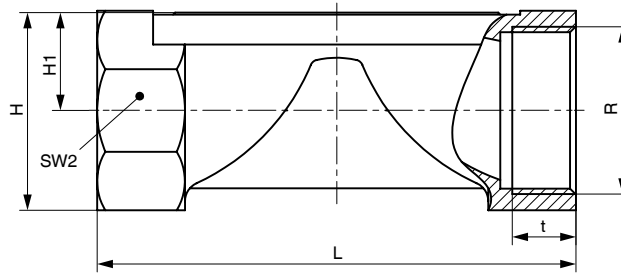

### Threaded connections, connection code 6, 62 Valve body material: investment casting (code 34), forged body (code 40)

MG	DN	H1	f*	øg*	ød1	Thread to DIN 405 R	Code 6 L	Code 62 L	Weight [kg]
10	10	12.5	30.0	13.5	10.0	RD 28 x 1/8	118	116	0.33
	15	12.5	30.0	13.5	16.0	RD 34 x 1/8	118	116	0.35

\* only for investment cast design

MG = diaphragm size

For materials see overview on page 8

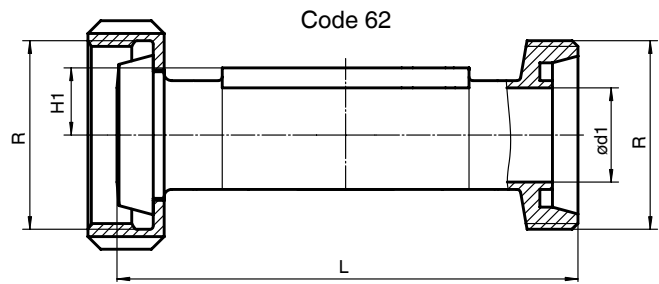
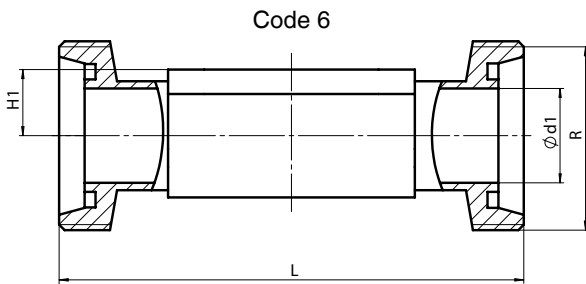



## Body dimensions [mm]

### Clamp connections, connection code 80, 82, 88, 8A Valve body material: Forged body (code 40, F4)

Pipe connection for clamp				ASME BPE						ISO 1127 / EN 10357 series C / DIN 11866 series B			EN 10357 series A (formerly DIN 11850 series 2) / DIN 11866 series A			Weight [kg]	
Clamp connection				ASME BPE						DIN 32676 series B			DIN 32676 series A				
Clamp connection code				80			88			82			8A				
MG	DN	NPS	H1	ød1	ød3	L	ød1	ød3	L	ød1	ød3	L	ød1	ød3	L		
10	10	3/8"	12.5	-	-	-	-	-	-	14.0	25.0	108.0	10	34.0	108.0	0.30	
	15	1/2"	12.5	9.40	25.0	88.9	9.40	25.0	108	18.1	50.5	108.0	16	34.0	108.0		0.43
	20	3/4"	12.5	15.75	25.0	101.6	15.75	25.0	117	-	-	-	-	-	-		

MG = diaphragm size

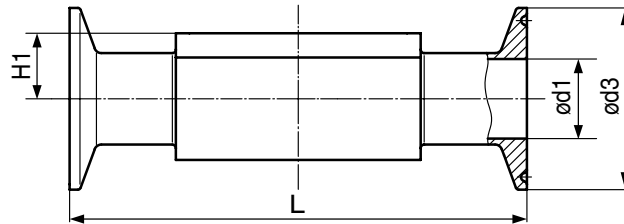

### Overview of valve bodies for GEMÜ 615

		Threaded connections				Spigots												Clamps			
Connection code		1	6	62	0	16	17	18	36	55	59	60	63	65	80	82	88	8A			
Material code		12	37	40	40	40	40	C3	40	40	40	C3	40	C3	40	40	40	40			
MG	DN																				
10	10	-	-	W	W	-	X	X	X	X	X	-	X	X	X	X	X	-	K	-	K
	12	X	X	-	-	-	-	-	-	-	-	-	-	-	-	-	-	-	-	-	-
	15	X	X	W	W	X	X	X	X	X	X	-	X	X	X	X	X	K	W	K	K
	20	-	-	-	-	-	-	-	-	-	-	X	X	X	-	-	-	K	-	K	-

X = Standard

K = Connections completely machined (not welded)

W = Welded construction

Availability of material code 42, F4: same as code 40

MG = diaphragm size