

Tank Bottom Valve, Metal

Construction

The 2/2-way metal tank bottom valve GEMÜ 643 is manually operated with a side mounted gear which has an optical position indicator as standard. The stainless steel valve body is machined from a single block (no welds) and is designed for welding directly into a tank bottom. The distance piece and the gearbox housing are made of stainless steel.

Features

- Suitable for inert and corrosive* liquid and gaseous media
- CIP/SIP cleaning and sterilizing capabilities

Advantages

- Tanks can be optimally drained, cleaned and sterilized by using the GEMÜ 643
- The temperature resistant plastic handwheel prevents burns injuries at high operating temperatures
- Compact design (ideal when space is at a premium)
- Tank bottom valve body also available with pneumatic or motorized actuator on request
- Bonnet can be rotated through 360°
- Versions according to ATEX on request
- Handwheel shaft extension by the user is possible

*see information on working medium on page 2



GEMÜ 643

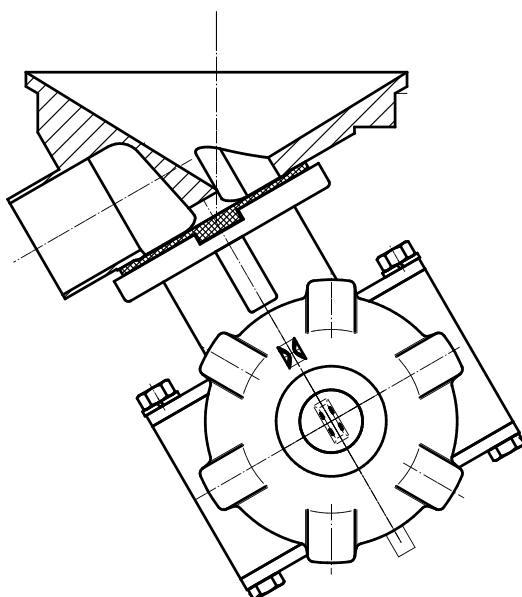

Technical data

Working medium

Corrosive, inert, gaseous and liquid media which have no negative impact on the physical and chemical properties of the body and diaphragm material.

Maximum permissible pressure of working medium, applied upstream

10 bar

Temperatures

Media temperature -10 ... 100 °C

Sterilisation temperature ⁽¹⁾

EPDM (Code 13) max. 150 °C ⁽²⁾, max. 60 min per cycle

EPDM (Code 17) max. 150 °C ⁽²⁾, max. 180 min per cycle

PTFE/EPDM (Code 54) max. 150 °C ⁽²⁾, no time limit per cycle

PTFE/EPDM (Code 5M) max. 150 °C ⁽²⁾, no time limit per cycle

¹ The sterilisation temperature is valid for steam (saturated steam) or superheated water.

² If the sterilisation temperatures listed above are applied to the EPDM diaphragms for longer periods of time, the service life of the diaphragms will be reduced. In these cases, maintenance cycles must be adapted accordingly.

This also applies to PTFE diaphragms exposed to high temperature fluctuations.

PTFE diaphragms can also be used as moisture barriers; however, this will reduce their service life.

The maintenance cycles must be adapted accordingly.

GEMÜ 555 and 505 globe valves are particularly suitable for use in the area of steam generation and distribution.

The following valve arrangement for interfaces between steam pipes and process pipes has proven itself over time:

A globe valve for shutting off steam pipes and a diaphragm valve as an interface to the process pipes.

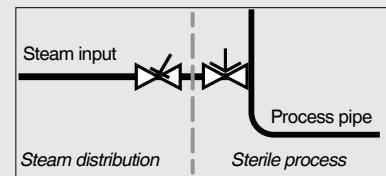

Ambient temperature

0 ... 60 °C

Nominal size [mm]	Bonnet Code	Operating pressure [bar]		Weight [kg]
		EPDM	PTFE	
15	2AT	0 - 10	0 - 6	3.0
20	2AT	0 - 10	0 - 6	3.0
25	2AT	0 - 10	0 - 6	3.0
32	3AT	0 - 10	0 - 6	6.0
40	3AT	0 - 10	0 - 6	6.0

Order data

Body configuration	Code
Tank valve body	B

Connection	Code
Butt weld spigots	
Spigots DIN	0
Spigots EN 10357 series B (formerly DIN 11850 series 1)	16
Spigot EN 10357 series A (formerly DIN 11850 series 2) / DIN 11866 series A	17
Spigots DIN 11850 series 3	18
Spigots SMS 3008	37
Spigot ASME BPE / DIN 11866 series C	59
Spigot ISO 1127 / EN 10357 series C / DIN 11866 series B	60
Spigots ANSI/ASME B36.19M Schedule 10s	63
Spigots ANSI/ASME B36.19M Schedule 40s	65

Valve body material	Code
1.4435 (F316L), forged body	40
1.4435 (BN2), forged body Δ Fe<0.5 %	42

Diaphragm material	Code
EPDM	13
EPDM	17
EPDM	36
PTFE/EPDM, two-piece	5M
Material complies with FDA requirements	

Control function	Code
Manually operated	0

Bonnet size	Code
Bonnet size 2AT (DN 15 - 25)	2AT
Bonnet size 3AT (DN 32 - 40)	3AT

Surface finish	Code
Code see page 4	

Order example	643	25	B	60	40	13	0	2AT	1503
Type	643								
Nominal size		25							
Body configuration (code)			B						
Connection (code)				60					
Valve body material (code)					40				
Diaphragm material (code)						13			
Control function (code)							0		
Bonnet size (code)								2AT	
Surface finish (code see page 4)									1503

Order data

Internal surface finishes for forged bodies ¹

Readings for Process Contact Surfaces	Mechanically polished ²		Electropolished	
	Hygienic class DIN 11866	Code	Hygienic class DIN 11866	Code
Ra ≤ 0.80 µm	H3	1502	HE3	1503
Ra ≤ 0.60 µm	-	1507	-	1508
Ra ≤ 0.40 µm	H4	1536	HE4	1537
Ra ≤ 0.25 µm ³	H5	1527	HE5	1516

Readings for Process Contact Surfaces acc. to ASME BPE 2016 ⁴	Mechanically polished ²		Electropolished	
	ASME BPE Surface Designation	Code	ASME BPE Surface Designation	Code
Ra Max. = 0.76 µm (30 µinch)	SF3	SF3	-	-
Ra Max. = 0.64 µm (25 µinch)	SF2	SF2	SF6	SF6
Ra Max. = 0.51 µm (20 µinch)	SF1	SF1	SF5	SF5
Ra Max. = 0.38 µm (15 µinch)	-	-	SF4	SF4

¹ Surface finishes of customized valve bodies may be limited in special cases.

² Or any other finishing method that meets the Ra value (acc. to ASME BPE).

³ The smallest possible Ra finish for pipe connections with an internal pipe diameter < 6 mm is 0.38 µm.

⁴ When using these surfaces, the bodies are marked according to the specifications of ASME BPE.

The surfaces are only available for valve bodies which are made of materials (e.g. GEMÜ material codes 40, 41, 44) and use connections (e.g. GEMÜ connection codes 59, 80, 88) according to ASME BPE.

Ra acc. to DIN EN ISO 4288 and ASME B46.1

Mounting position

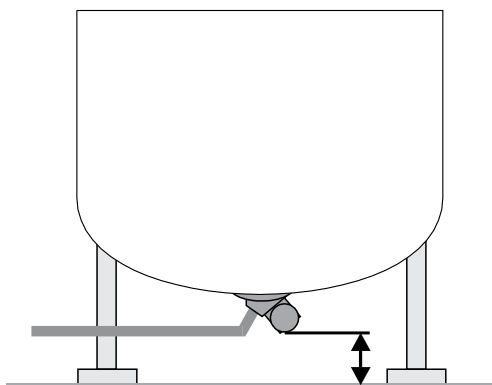

Mounting position (with handwheel shaft extension by user)

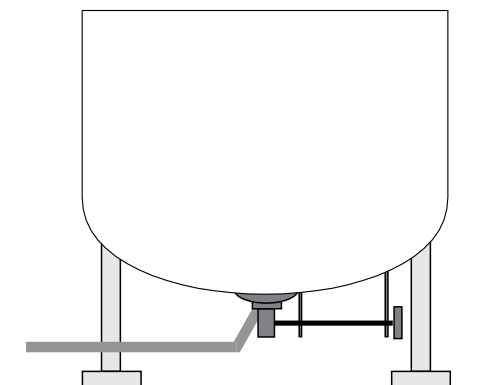

Dimensions [mm]

**Butt weld spigots, connection code 0, 16, 17, 18, 60
Valve body material: Forged body (code 40)**

Pipe standard							DIN		EN 10357 series B (formerly DIN 11850 series 1)		EN 10357 series A (formerly DIN 11850 series 2) / DIN 11866 series A		DIN 11850 Series 3		ISO 1127 / EN 10357 series C / DIN 11866 series B	
Connection code							0		16		17		18		60	
MG	DN	A3	B3	ø B	SP	c	ød	s	ød	s	ød	s	ød	s	ød	s
25	15	166	104	120	6	25	18	1.5	18	1.0	19	1.5	20	2.0	21.3	1.6
	20	166	104	120	6	25	22	1.5	22	1.0	23	1.5	24	2.0	26.9	1.6
	25	166	104	120	6	25	28	1.5	28	1.0	29	1.5	30	2.0	33.7	2.0
40	32	190	110	160	6	25	34	1.5	34	1.0	35	1.5	36	2.0	42.4	2.0
	40	190	110	160	6	25	40	1.5	40	1.0	41	1.5	42	2.0	48.3	2.0

MG = diaphragm size

**Butt weld spigots, connection code 37, 59, 63, 65
Valve body material: Forged body (code 40)**

Pipe standard							SMS 3008		ASME BPE / DIN 11866 series C		ANSI/ASME B36.19M Schedule 10s		ANSI/ASME B36.19M Schedule 10s	
Connection code							37		59		63		65	
MG	DN	A3	B3	ø B	SP	c	ød	s	ød	s	ød	s	ød	s
25	15	166	104	120	6	25	-	-	-	-	21.3	2.11	21.3	2.77
	20	166	104	120	6	25	-	-	19.05	1.65	26.7	2.11	26.7	2.87
	25	166	104	120	6	25	25.0	1.2	25.40	1.65	33.4	2.77	33.4	3.38
40	32	190	110	160	6	25	33.7	1.2	-	-	42.2	2.77	42.2	3.56
	40	190	110	160	6	25	38.0	1.2	38.10	1.65	48.3	2.77	48.3	3.68

MG = diaphragm size

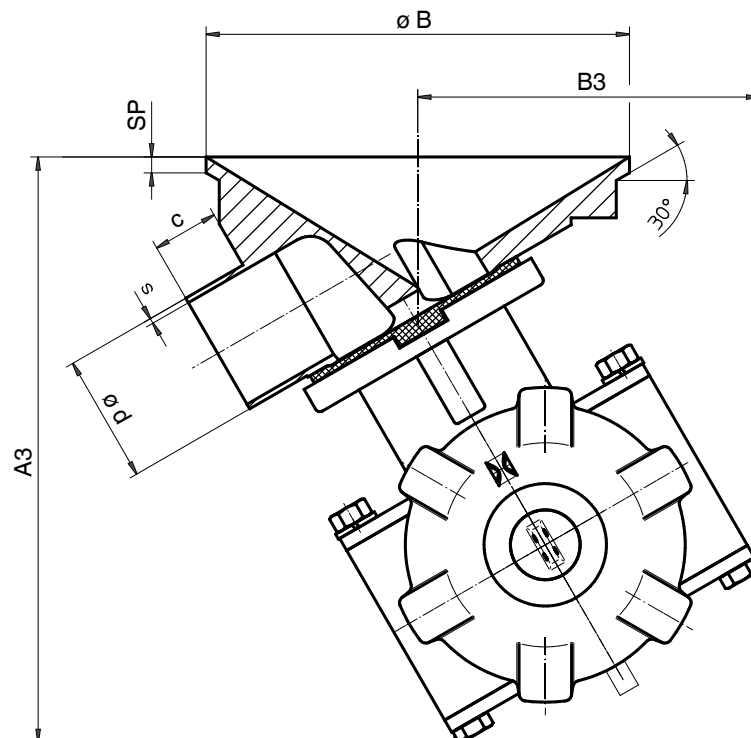

Overview of valve bodies for GEMÜ 643

		Spigots								
Connection code		0	16	17	18	37	59	60	63	65
Material code		40	40	40	40	40	40	40	40	40
MG	DN									
25	15	X	X	X	X	-	-	X	X	X
	20	X	X	X	X	-	X	X	X	X
	25	X	X	X	X	X	X	X	X	X
40	32	X	X	X	X	X	-	X	X	X
	40	X	X	X	X	X	X	X	X	X

Availability of material code 42: same as code 40

MG = diaphragm size

Shaft extension (by user)

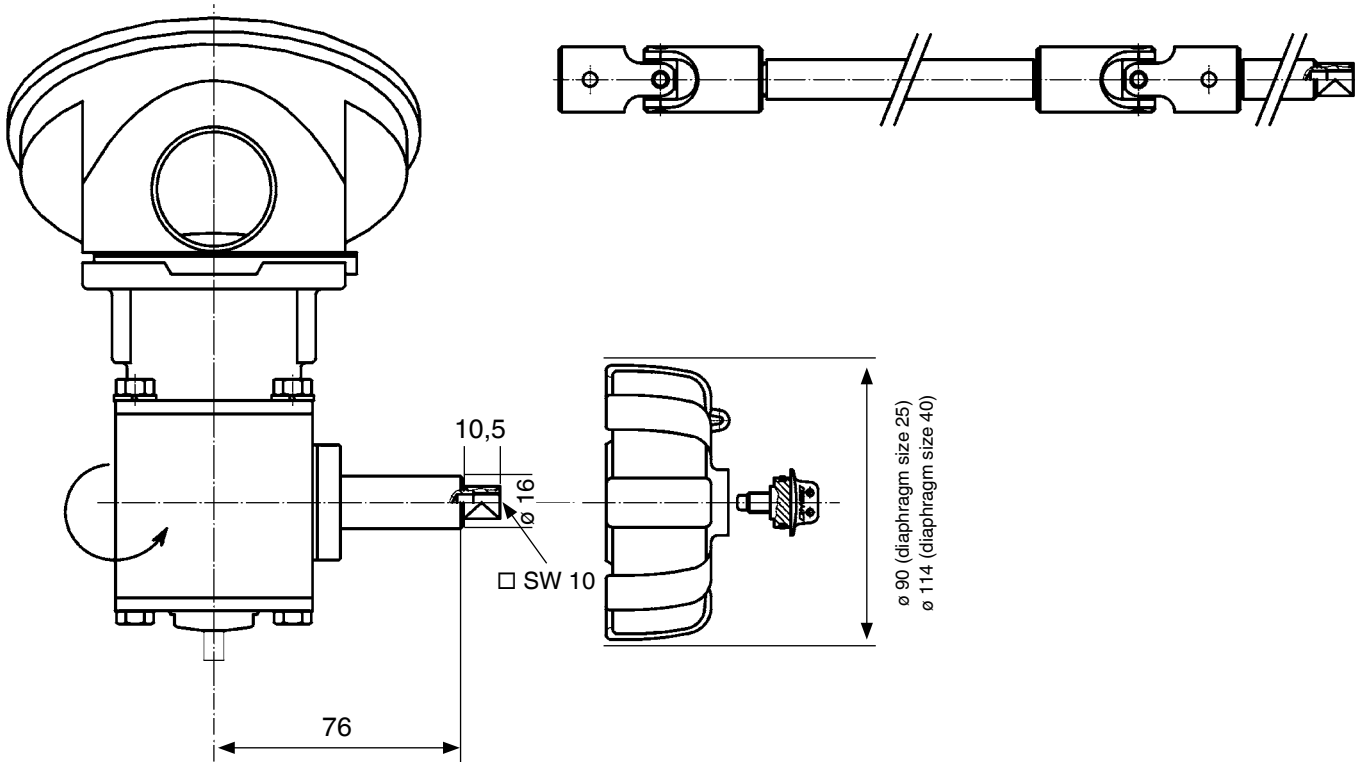

Attention!

When the user installs a handwheel extension care should be taken that it has sufficient bearing points.

Torques for shaft extension:

Bonnet size 2AT 11 Nm

Bonnet size 3AT 14 Nm